



扫描二维码
关注康力电梯门户网站
Scan the QR code and pay attention to
CANNY ELEVATOR Portal Website.



扫描二维码
关注康力电梯微信公众号
Scan the QR code and pay attention to
CANNY ELEVATOR WeChat Public Number

KONL® 康力电梯
CANNY ELEVATOR

KLT

公共交通型自动扶梯
PUBLIC TRAFFIC TYPE
ESCALATOR

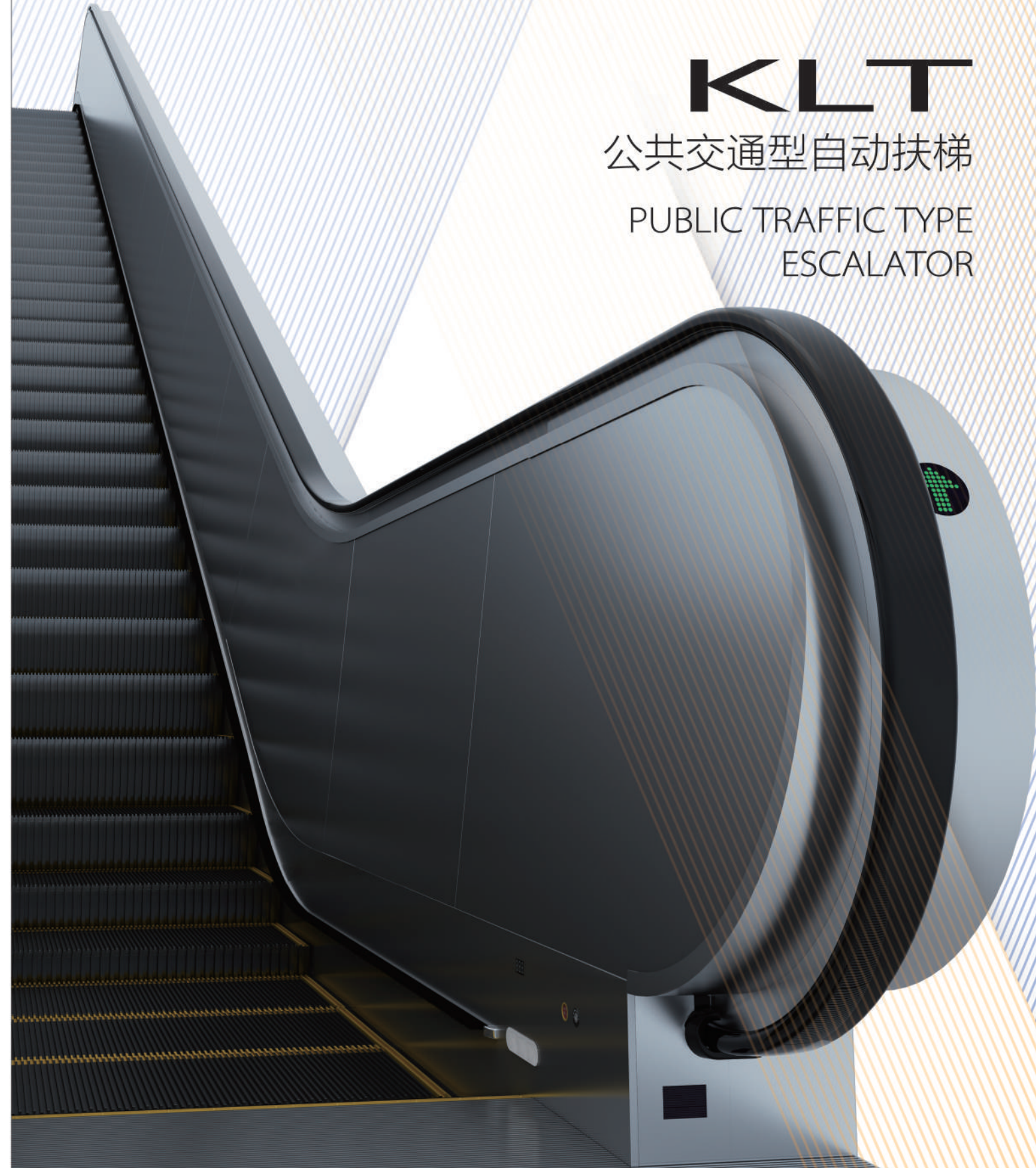

康力电梯股份有限公司 CANNY ELEVATOR CO.,LTD.

◎地址：江苏省滨湖高新技术产业开发区康力大道888号
◎电话：0512-63290000
◎传真：0512-63293938
◎网址：www.canny-elevator.com
◎电子信箱：(国内) marketing@canny-elevator.com
(国外) export-canny@163.com
export@canny-elevator.com
◎400客户服务热线：400-188-2367
◎邮编：215213

◎Add: No.888, Kangli Road, FOHO New & Hi-Tech Industrial
Development Zone, Jiangsu Province, China.
◎Tel: +86-512-63290000 63297851
◎Fax: +86-512-63299709
◎URL: www.canny-elevator.com
◎E-mail: export-canny@163.com
export@canny-elevator.com
◎P.C: 215213

本书为一般信息类出版物，我们保留随时更改产品设计和说明的权利，所有图片和颜色可能与实物有所不同，请以实物为准。
康力电梯股份有限公司 © 版权所有 2016-V1.0版

KLT公共交通型自动扶梯
Public Traffic
Type Escalator

享受每一次到达的愉悦

Enjoy the Pleasure of Each Arrival



地铁



火车站



机场



天桥

性能卓越，出色输送

KLT公共交通型自动扶梯基于和谐运载的理念，外在结构合理，内在高效驱动，不断提升产品技艺，苛求产品细节点滴，力求呈现最完美的乘坐感受。

康力KLT系列，精心的梯路设计，完美的时尚表现，为广大客户提供了高端大方，品质一流，性能出众的公共交通型自动扶梯产品。

Remarkable Performance, Excellent Transportation

Adhering to the concept of harmonious transportation, KLT public traffic escalators adopt reasonable external structure and high efficient internal drive, constantly improve product craftsmanship, raise strict demands on details, and strive to provide the most perfect user experience. CANNY adopts careful ladder design and perfect fashion elements for KLT series, providing customers with high-end public traffic escalators that have good appearance, top quality and superior performance.



Excellent System, Extraordinary Performance Brings High-Efficient and Energy-Saving Operation

- ◆ Excellent drive system and high-power main engine ensure the higher transmission efficiency, stronger driving force and lower power consumption.
- ◆ New microwave frequency conversion technology protects it from the interference of environment and other factors, making escalator more sensitive, reliable and energy-saving at the same time, and ensuring safety of operation.
- ◆ Advanced control system enables it to be more scalable and stable, to have further detailed the fault detection functions, thereby providing higher safety performance. (Optional)



故障检测功能
Fault Detection Function

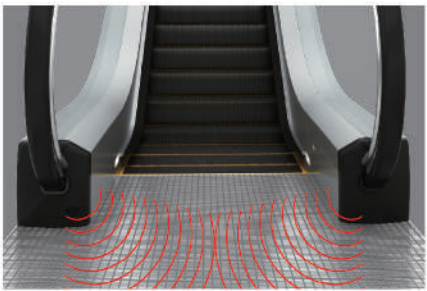

新型微波变频技术
New Microwave Inverter Technology

优越的变频控制技术（选配）

在空载情况下，公共交通型自动扶梯以低速运行，当检测到乘客接近时即恢复正常速度运行。在人流稀少的场合通常能够节能60%。

Superior Frequency Control Technology (Optional)

Under no-load conditions, public traffic escalator runs at low speed; when it detects passengers, it will run at normal speed. In occasions of small passenger flow, it usually saves 60% of energy.

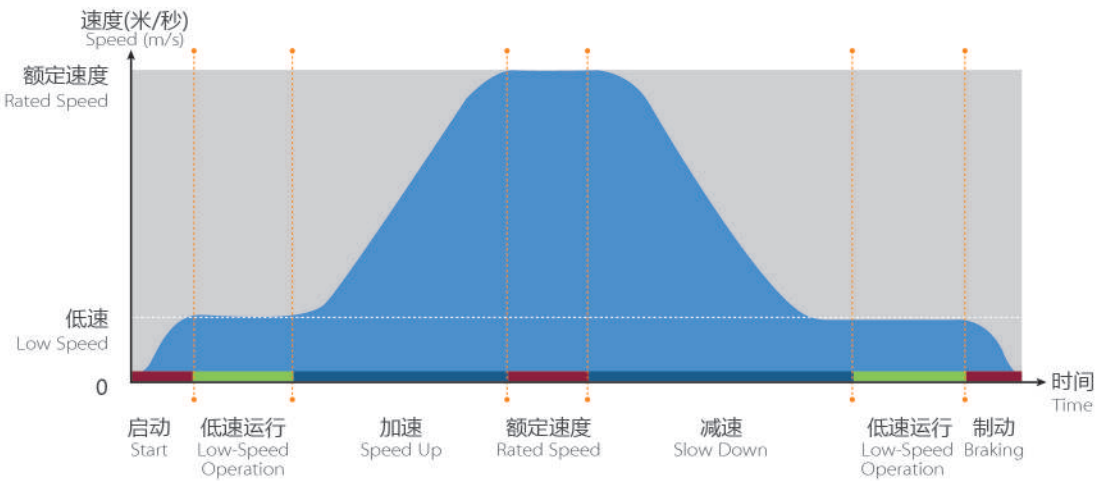

系统卓越，表现非凡

使每一次运行高效节能

- ◆ 出色的驱动系统，大功率主机，保证整机传动效率更高，驱动力更强，能耗更低。
- ◆ 新型微波变频技术，打破环境和其他因素干扰，更加灵敏可靠，节能同时，保障乘梯安全。
- ◆ 先进的控制系统，扩展性更强，稳定性更高，故障检测功能更加细化，从而安全性能更高。（选配）

能耗低

驱动系统和主机

抗干扰

微波变频技术

性能高

控制系统（选配）



精湛品质，匠心独运

让每一个细节完美呈现



机器人焊接
Robot Welding



滚轴梯级链
Roller Step Chain

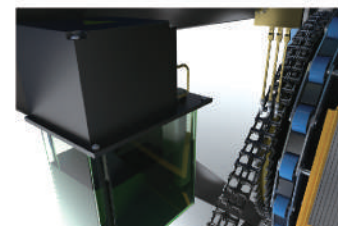

PLC控制自动加油
PLC Automatic lubrication

大圆弧半径回转扶手导轨

匹配使用滚动群轮组，有效的降低扶手带弯曲应力，延长扶手带的使用寿命。

Large Radius Rotary Handrail Guide Rail

It is matched with rolling wheel group, effectively reducing the bending stress of handrail belt, and prolonging the service life of handrail belt.

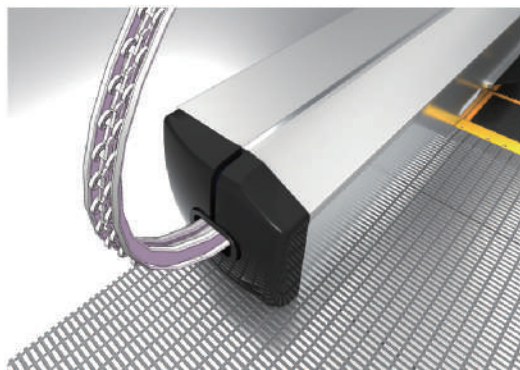

Φ80的梯级轮及链条轮

采用直径为Φ80的梯级轮及链条轮，能够有效降低轮压，延长扶梯使用寿命。

Φ80 Step Roller and Chain Roller

It adopts step roller and chain roller with a diameter of Φ80, can effectively reduce the wheel pressure and prolong the service life of escalator.

- ◆ 整机结构严格通过计算机有限元分析，桁架采用机器人焊接技术，大大提升制造工艺，具有品质精益、坚固耐用等优点。
- ◆ 滚轮内置于专门设计的滚轴梯级链，有效降低驱动运行时的噪音；大提升高度时，使用铝芯滚轮强度更高，使用寿命更长。
- ◆ PLC控制自动加油润滑系统，实现了在公共交通型自动扶梯运行过程中给传动链理想的自动润滑，延长传动机构的使用寿命。
- ◆ 护壁板内部增贴了新型隔音橡胶，有效阻隔机器传动和部件摩擦所产生的噪音。
- ◆ 特别设计的油水分离器，雨水通过油水分离器排出，油污进行定期清洗，减少油污，保护环境。（室外梯选配）

Superb Quality, Real Ingenuity Present Perfection Through Details

- ◆ The whole structure passes the strict computer finite element analysis, the truss adopts robotic robot welding technology, thus greatly enhancing the manufacturing process and making it more sturdy, wearable and beautiful.
- ◆ The special built-in roller step chain can effectively reduce the noise during driving operation, increase lifting height, increase the strength and service life of aluminum-core wheels under high lifting distance.
- ◆ PLC automatic lubrication system provides ideal lubrication for gearing chain during operation, extends the service life of transmission device.
- ◆ New soundproof rubber is posted on the internal baseboards, thus effectively blocking noise generated by machine transmission and components friction.
- ◆ The specially designed oil-water separator can discharge rainwater, making greasy dirt can be regularly cleaned, thus reducing oil contamination and protecting the environment. (outdoor escalator optional)

Attentive Consideration, All-round Safety

To Think More for Each Arrival

- ◆ High-precision escalator path leans towards guiderail system, ensures appropriate clearance between step and skirting panel, reduces the risk of foreign material being stuck in the gap between step and skirting panel.
- ◆ Advanced safety circuit board is adopted to provide real-time monitoring of the safety protection devices of public traffic escalator, to timely eliminate operational risks, thus ensuring the safety of passengers.
- ◆ When the public transport type escalator failure emergency occurs, press the emergency stop button, immediately stop public traffic heavy-duty escalator running, to prevent further accidents.
- ◆ If any fault occurs, the fault code will be displayed on the fault screen, and the fault location will be accurately determined, thus greatly improving maintenance efficiency.
- ◆ Running direction indicator are placed at the handrail belt entrance to indicate the operation or stop of escalator, so as to enable passengers to have safe and free user experience. (Optional)



高精度梯路侧向导轨
High-precision Escalator Path Leans
Towards Guiderail

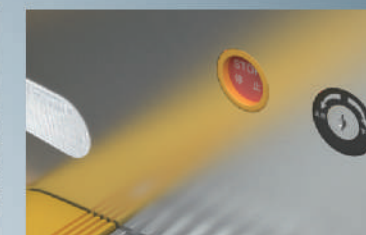

急停按钮
Emergency Stop Button



运行方向指示灯 (选配)
Escalator Running Direction (Optional)



深思熟虑，周密安全

为每一次到达多想一步

- ◆ 高精度梯路侧向导轨系统保证梯级与裙板间保持合适的间隙，降低了裙板与梯级间隙异物夹入的危险。
- ◆ 采用先进的安全电路板，对公共交通型自动扶梯安全保护装置进行实时监控，及时消除运行隐患，确保乘客安全。
- ◆ 当公共交通型自动扶梯发生紧急故障时，可按下急停按钮，立刻停止公共交通型自动扶梯运行，防止更大的事故发生。
- ◆ 当有故障发生时，故障代码就会显示在故障屏幕上，准确判断故障部位，大大提高维修保养效率。
- ◆ 运行方向指示灯位于扶手带入口处，以显示运行或禁行指示，确保乘客安全自如地乘坐。(选配)

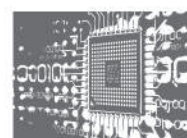

安全电路板



故障显示屏



运行方向指示灯 (选配)



围裙板刷

能够有效避免乘客的鞋子碰擦围裙板，并能安全有效地防止异物被带入梯级，发生意外或电梯故障。

Skirting Brush

It can effectively protect passengers' shoes from grazing skirting panel, and can safely and effectively prevent foreign objects from being brought into the escalator and causing accident or elevator malfunction.

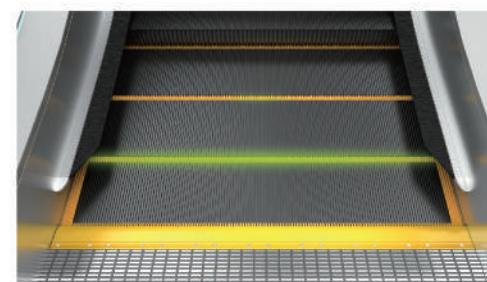

梯级警戒灯

当两连接的梯级运行错开时，梯级警戒灯光便从梯级的齿口中照出，帮助乘客识别梯级进出口水平段，提高乘梯安全。

Step Warning Light

When two adjacent steps are staggered, step warning lights illuminate from the teeth of steps, help passengers identify the entrance and exit of escalator, thus improving safety.



居高临下，俯瞰卓越

与每一处环境始终相得益彰

领先技术优势与人性追求高度统一，创造更平稳舒适，高效节能，安全可靠的公共交通典范。

Commanding Position, Overlooking Excellence

Always Brings Out the Best Environment

The combination of leading technological superiority with high degree of humanity creates a more stable, comfortable, energy-efficient public transport tools.

美学设计，人性关怀

直扶手、斜扶手的造型选择，配合多种扶手带颜色和护壁板颜色，打造多样化个性需求。

Aesthetic Design, Human Caring

Straight handrails and inclined handrails, matched with handrail belts and balustrade with optional colors, meet diverse individual needs.

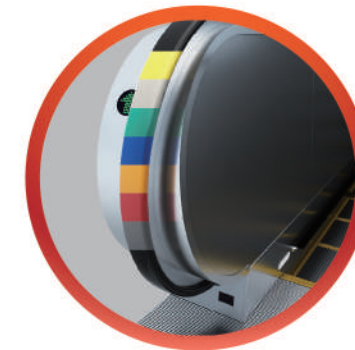

斜扶手
Oblique Inclined Handrail

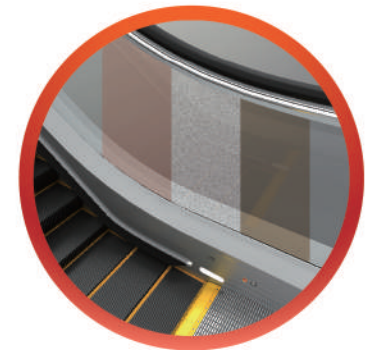

玻璃直扶手
Glass Vertical Handrail

LED照明（选配）

扶手照明、围裙照明、梳齿照明均采用LED照明系统，在节能环保的同时，增添时尚美感，演绎亮丽风尚。

LED Lighting (Optional)

Handrail lighting, apron skirt lighting and comb lighting adopt LED lighting system, which can save energy and protect environment, while increasing stylish beauty and interpreting fashion.

扶手带入口

创新型扶手带入口设计，极具质感和流畅的工业美学，赋予公共交通型自动扶梯更多的灵活性和高雅气质。

Handrail Belt Entrance

The innovative handrail belt entrance design is of great texture and smooth industrial aesthetic beauty, providing public traffic escalator with more spirituality and elegance.

多规格梯级宽度

根据使用场合和环境灵活定制您的梯级宽度。（600mm、800mm、1000mm）

Multiple-specifications Step Width

The Step width (600mm, 800mm, 1000mm) can be chosen flexibly according to the application occasion and environment.

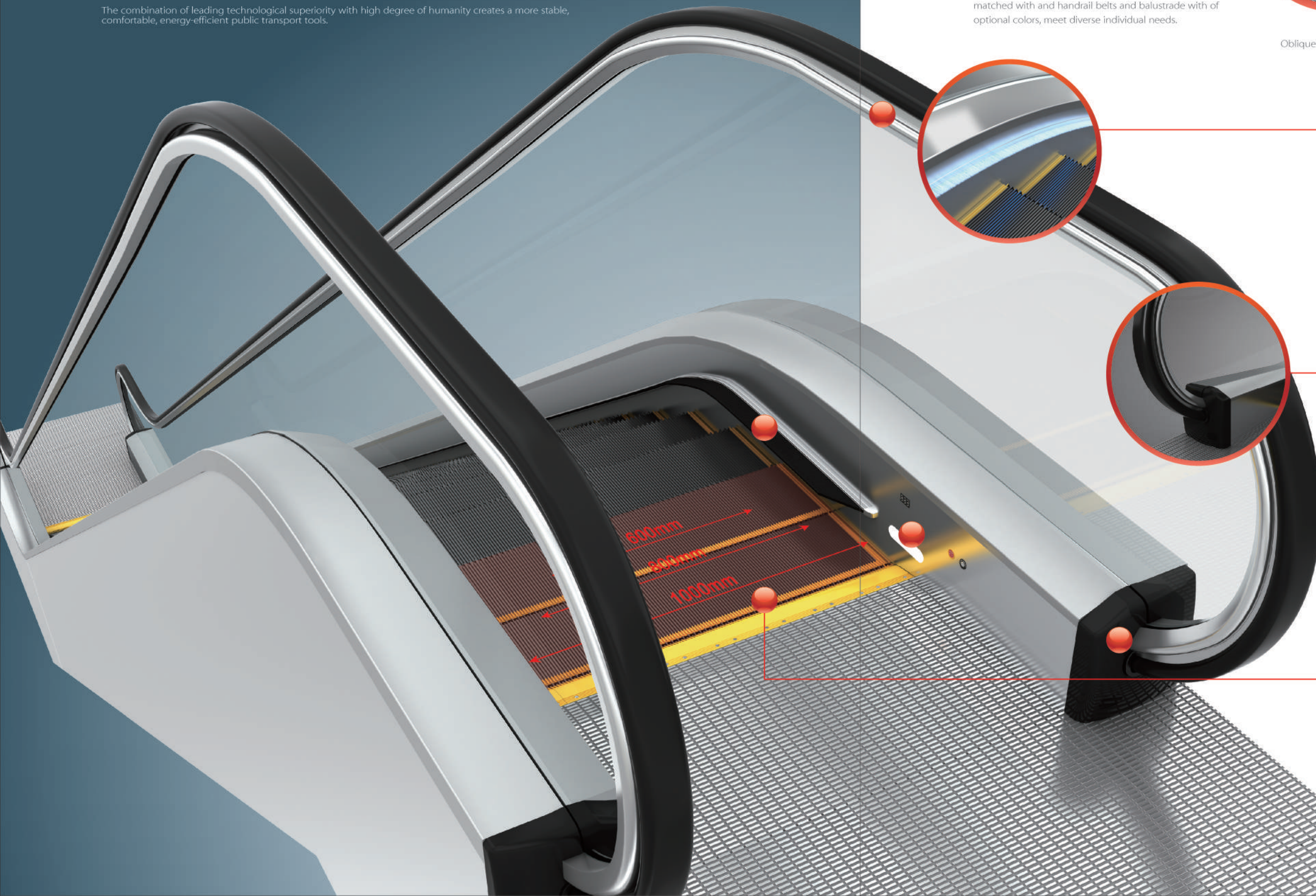

安全装置

Safety Device

标准安全装置	Standard Safety Device
1 缺相、错相保护	Lack of Phase, Error Phase Protection
2 马达超载保护	Motor Over-load Protection
3 电器回路保护	Electrical Appliance Loop Protection
4 扶手带入口保护	Handrail Belt Protection
5 梳齿板安全保护装置	Comb Plate Safety Device
6 梯级塌陷保护装置	Step Sagging Protection Device
7 驱动链断裂保护	Broken Drive-chain Safety Device
8 梯级链断裂保护	Broken Step Chain Protection
9 超速保护	Over-speed Protection
10 非操作逆转保护	Direction Reversal Protection
11 警界线	Security Line
12 紧急停止按钮	Emergency Stop Button
13 围裙板保护	Skirt Panel Protection
14 制动器保护	Brake Protection

标准安全装置	Standard Safety Device
15 检修安全开关	Safety Inspection Switch
16 梯级照明	Step Illumination
17 启动警铃装置	Alarm Bell Starting Device
18 前沿板打开保护装置	Landing Plate Contact
19 扶手带速度监控	Handrail Belt Speed Monitor
20 围裙板刷	Skirt Panel Brush
21 制动距离检测	Braking Distance Inspection
22 梯级缺失监测装置	Step Missing Detection

可选用的安全装置	Optional Safety Device
23 防火卷帘门联动装置	Fire Shutter Door Interlocks
24 下部机房水位检测 (室外梯)	Lower Machine Room Water Level Detection (Outdoor Escalator)
25 附加制动器 (6m<H 时必须配备)	Auxiliary Brake (It Should be Allocated with the Emergency Brake when 6m<H)

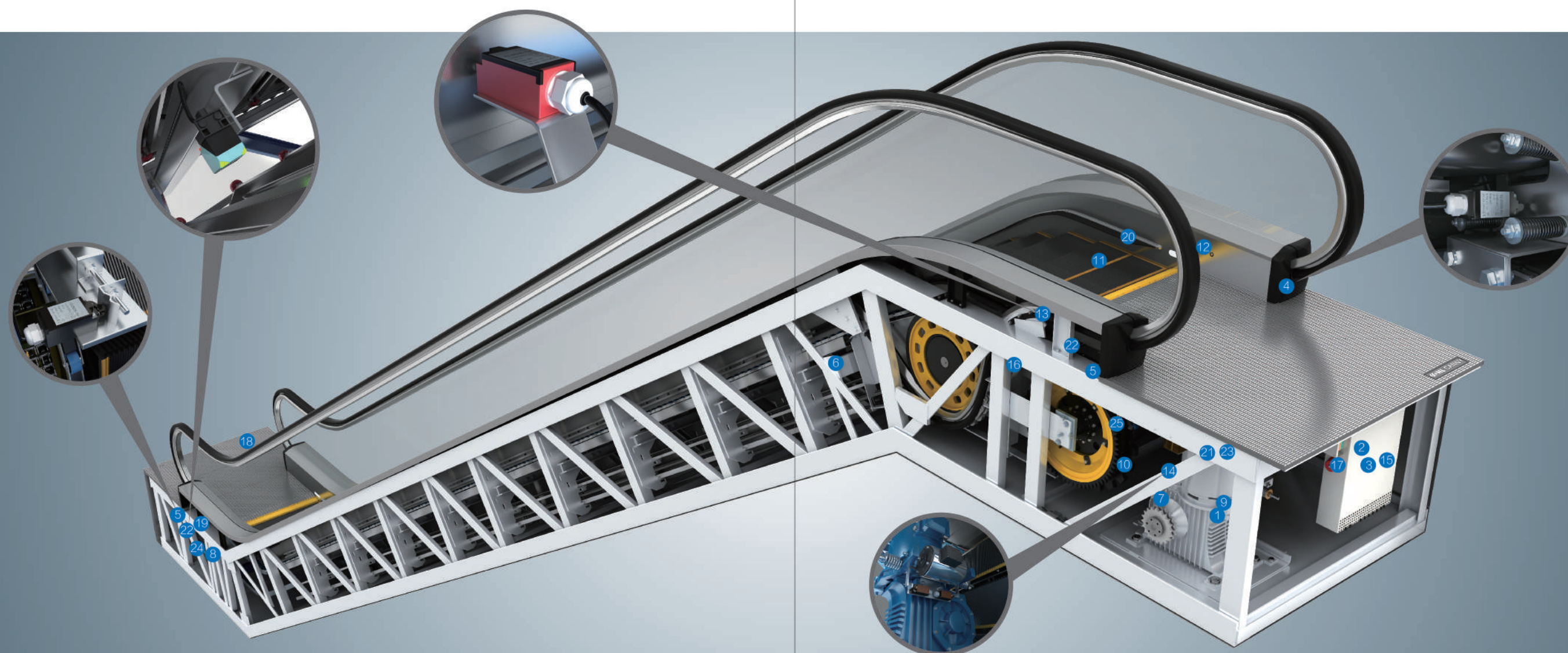

KLT-M 直扶手 公共交通型自动扶梯

KLT-M Vertical Handrail Public Traffic Escalator



自动扶梯规格表 Escalator Specification Table

型号 Model	KLT-M (室内) Indoor	KLT-XF (室内) Indoor	KLT-M (室外) Outdoor	KLT-XF (室外) Outdoor
倾斜角度 Angle of Inclination	30° /27.3° /23.2°	30° /27.3° /23.2°	30° /27.3° /23.2°	30° /27.3° /23.2°
梯级宽度 (mm) Step Width (mm)	1000/800/600	1000/800/600	1000/800/600	1000/800/600
额定速度m/s Rated Speed (m/s)	0.5/0.65	0.5/0.65	0.5/0.65	0.5/0.65
水平梯级数 Horizontal Step Number	3	3	3	3
最大提升高度m Max. Rise H (m)	16	16	16	16

自动扶梯配置表 Escalator Configuration Table

型号 Model	KLT-M (室内) Indoor	KLT-XF (室内) Indoor
踏板、梳齿板类型(标配) Types of Pedals and Comb Plate (Standard)	SUS430不锈钢贴片楼层盖板 SUS430 Stainless Steel Patch Floor Cover Plate Decking	SUS430不锈钢贴片楼层盖板 SUS430 Stainless Steel Patch Floor Cover Plate Decking
踏板、梳齿板类型(选配) Types of Pedals and Comb Plate (Optional)	全铝合金楼层盖板/铝合金贴片楼层盖板/ SUS304不锈钢贴片楼层盖板 All-aluminum Floor Cover Plate Decking/Aluminum Alloy Floor Cover Plate Decking/SUS304 Stainless Steel Patch Floor Cover Plate Decking	全铝合金楼层盖板/铝合金贴片楼层盖板/ SUS304不锈钢贴片楼层盖板 All-aluminum Floor Cover Plate Decking/Aluminum Alloy Floor Cover Plate Decking/SUS304 Stainless Steel Patch Floor Cover Plate Decking
围裙板(标配) Skirting Panel (Standard)	SUS430 不锈钢围裙板 SUS430 Stainless Skirting Panel	SUS430 不锈钢围裙板 SUS430 Stainless Skirting Panel
围裙板(选配) Skirting Panel (Optional)	SUS304 不锈钢围裙板 SUS304 Stainless Skirting Panel	SUS304 不锈钢围裙板 SUS304 Stainless Skirting Panel
梯级(标配) Step (Standard)	黑色不锈钢 Black Stainless Steel	黑色不锈钢 Black Stainless Steel
梯级(选配) Step (Optional)	铝合金黑色/铝合金银灰色 Black Aluminum / Silver Grey Aluminum Alloy	铝合金黑色/铝合金银灰色 Black Aluminum / Silver Grey Aluminum Alloy
扶手带(标配) Handrail (Standard)	黑色 Black	黑色 Black
扶手带(选配) Handrail (Optional)	其他颜色 Other Colors	其他颜色 Other Colors
扶手护栏(标配) Handrail Guardrail (Standard)	垂直 Vertical	斜扶手 Oblique Inclined Handrail
扶手护栏(选配) Handrail Guardrail (Optional)	—	—
护壁板(标配) Balustrade Panel (Standard)	10mm 钢化无色安全玻璃 10mm Toughened Tempering Safety Glass Colorless	SUS430 不锈钢斜扶护壁板 SUS430 Stainless Oblique Wallboard Inclined Balustrade
护壁板(选配) Balustrade Panel (Optional)	—	SUS304 不锈钢斜扶护壁板 SUS304 Stainless Oblique Wallboard Inclined Balustrade

型号 Model	KLT-M (室外) Outdoor	KLT-XF (室外) Outdoor
踏板、梳齿板类型(标配) Types of Pedals and Comb Plate (Standard)	SUS304不锈钢贴片楼层盖板 SUS304 Stainless Steel Patch Floor Cover Plate Decking	SUS304不锈钢贴片楼层盖板 SUS304 Stainless Steel Patch Floor Cover Plate Decking
踏板、梳齿板类型(选配) Types of Pedals and Comb Plate (Optional)	全铝合金楼层盖板/铝合金贴片楼层盖板 All-aluminum Floor Cover Plate Decking/ Aluminum Alloy Floor Cover Plate Decking	全铝合金楼层盖板/铝合金贴片楼层盖板 All-aluminum Floor Cover Plate Decking/ Aluminum Alloy Floor Cover Plate Decking
围裙板(标配) Skirting Panel (Standard)	SUS304 不锈钢围裙板 SUS304 Stainless Skirting Panel	SUS304 不锈钢围裙板 SUS304 Stainless Skirting Panel
围裙板(选配) Skirting Panel (Optional)	—	—
梯级(标配) Step (Standard)	铝合金银灰色 Silver Grey Aluminum Alloy	铝合金银灰色 Silver Grey Aluminum Alloy
梯级(选配) Step (Optional)	铝合金黑色 Black Aluminum	铝合金黑色 Black Aluminum
扶手带(标配) Handrail (Standard)	黑色 Black	黑色 Black
扶手带(选配) Handrail (Optional)	其他颜色 Other Colors	其他颜色 Other Colors
扶手护栏(标配) Handrail Guardrail (Standard)	垂直 Vertical	斜扶手 Oblique Inclined Handrail
扶手护栏(选配) Handrail Guardrail (Optional)	—	—
护壁板(标配) Balustrade Panel (Standard)	10mm 钢化无色安全玻璃 10mm Toughened Tempering Safety Glass Colorless	SUS304 不锈钢斜扶护壁板 SUS304 Stainless Oblique Wallboard Inclined Balustrade
护壁板(选配) Balustrade Panel (Optional)	—	—

KLT-XF 斜扶手 公共交通型自动扶梯

KLT-XF Oblique Inclined Handrail Public Traffic Escalator

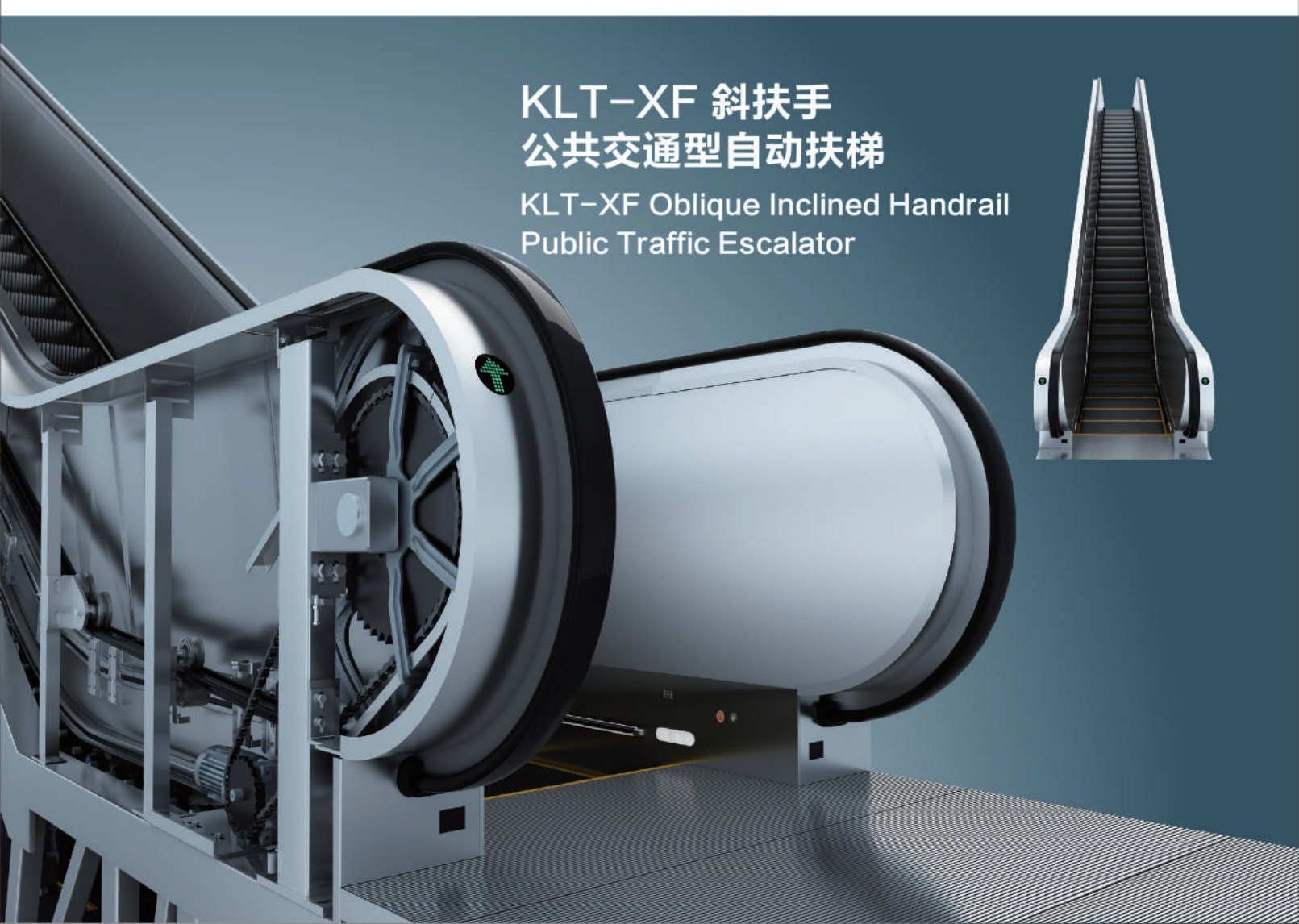

独特设计，品鉴美感

Unique Design, Taste of Beauty

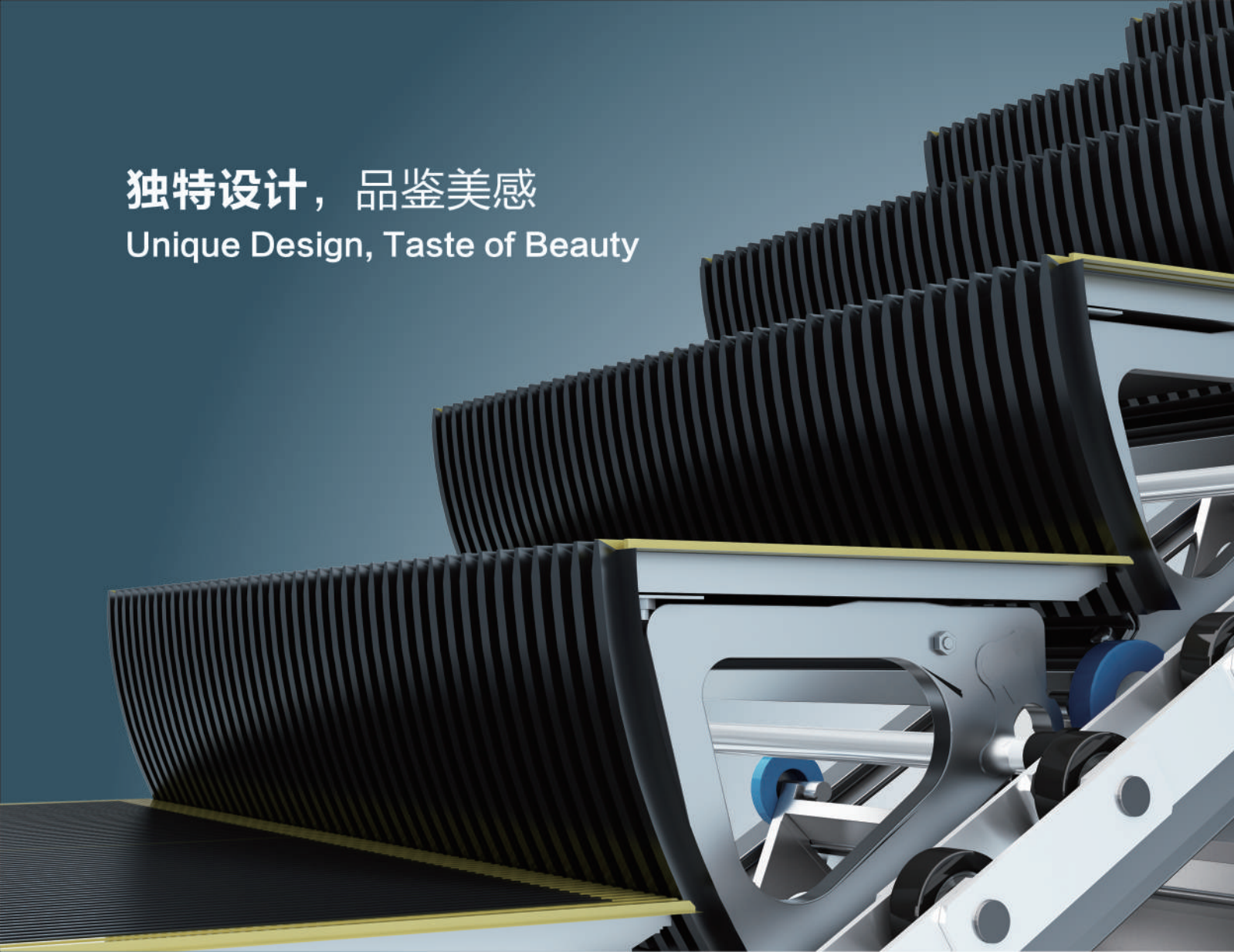

梯级 Step

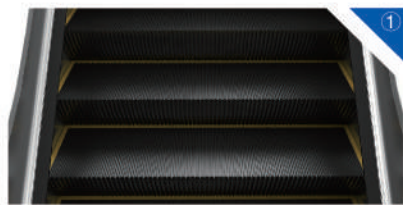

黑色不锈钢C型塑料边框 (室内梯标配)
Black Stainless Steel C-Type Plastic Frame
(Standard for Indoor Escalator)

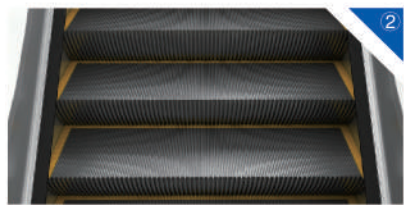

银灰色铝合金C型边框 (室外梯标配)
Silver Grey Aluminum Alloy C-Type Frame
(Standard for Outdoor Escalator)

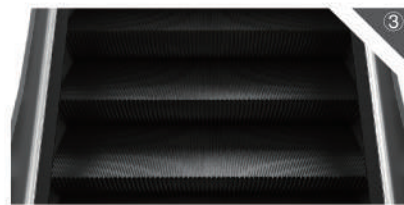

黑色铝合金 (选配)
Black Aluminum Alloy (Optional)

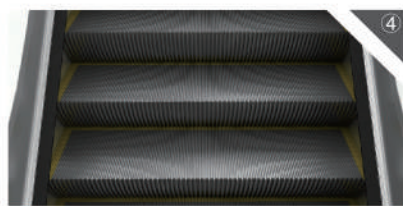

边框喷涂C型 (选配)
Frame Spraying C-Type
(Optional)

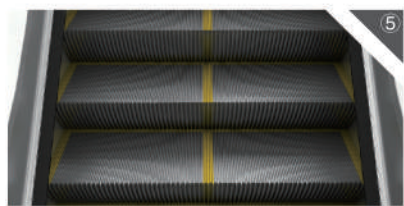

边框喷涂E型 (选配)
Frame Spraying E-Type
(Optional)

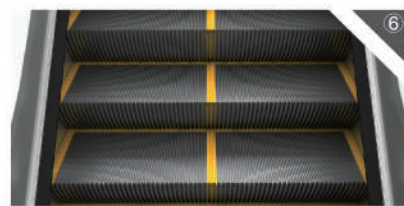

边框黄色塑料E型 (选配)
Frame Yellow Plastic E-Type
(Optional)

扶手带颜色 Handrail Color

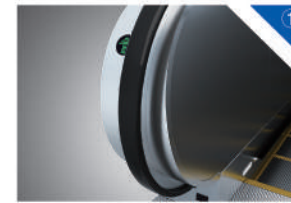

黑色 (标配)
Black (Standard)

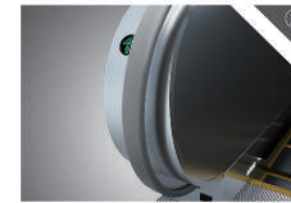

灰色 (选配)
Gray (Optional)

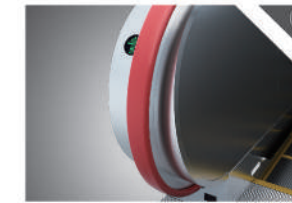

红色 (选配)
Red (Optional)

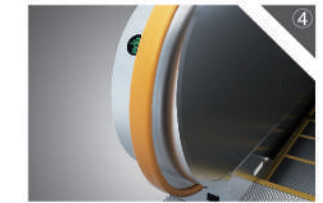

橙色 (选配)
Orange (Optional)

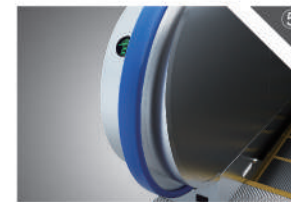

蓝色 (选配)
Blue (Optional)

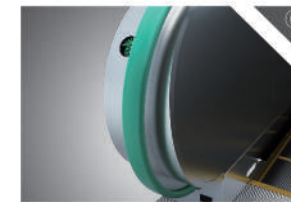

浅绿蓝 (选配)
Greenish Blue (Optional)

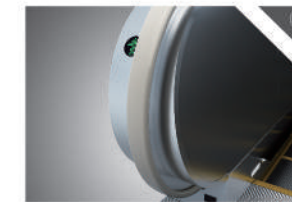

浅褐色 (选配)
Light Brown (Optional)

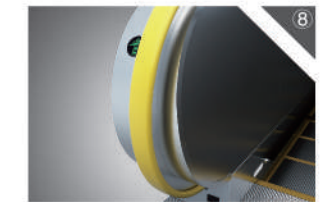

黄色 (选配)
Yellow (Optional)

扶手照明 Handrail Lighting

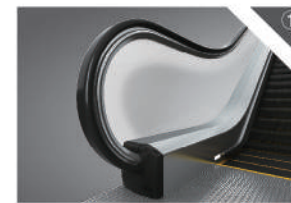

白色 (选配)
White (Optional)

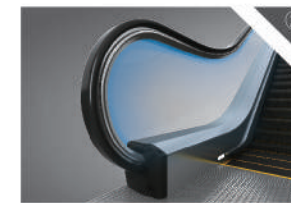

蓝色 (选配)
Blue (Optional)

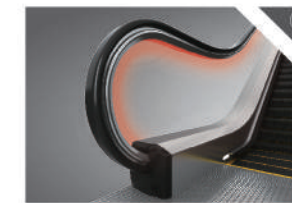

红色 (选配)
Red (Optional)

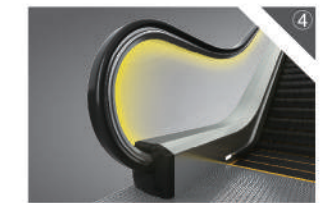

黄色 (选配)
Yellow (Optional)

围裙照明 Skirting Panel Lighting

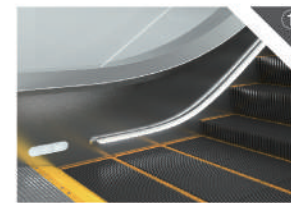

白色 (选配)
White (Optional)

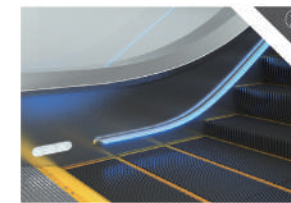

蓝色 (选配)
Blue (Optional)

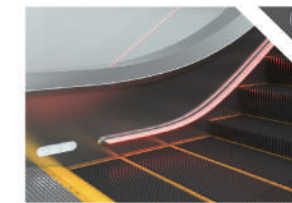

红色 (选配)
Red (Optional)

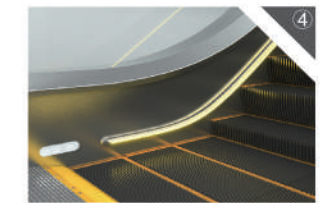

黄色 (选配)
Yellow (Optional)

注：图片系电脑绘制，可能与实际略有不同，以实物为准。
Note: Pictures have been drawn by computer. It might be slightly different from actual colors. Please take real product as criterion.

独特设计, 品鉴美感

Unique Design, Taste of Beauty

梳齿 Comb Teeth

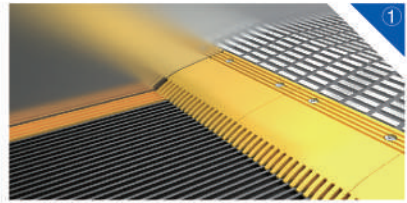

黄色塑料 (室内梯标配)
Yellow Plastic (Standard for Indoor Escalator)

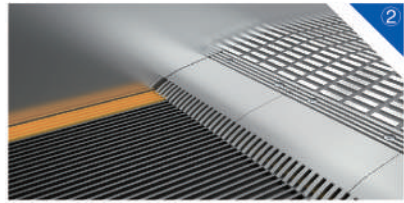

铝 (室外梯标配)
Aluminum (Standard for Outdoor Escalator)

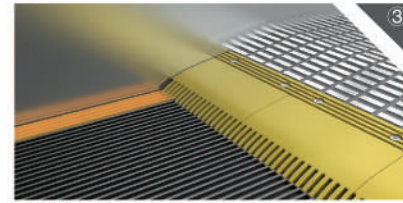

铝表面黄色喷漆 (选配)
Aluminum Surface Yellow Paint (Optional)

梳齿照明 Comb Teeth Lighting



白色LED (选配)
White LED (Optional)



黄色LED (选配)
Yellow LED (Optional)

护壁板 Balustrade Panel

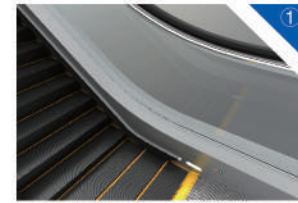

无色安全玻璃 (直扶手标配)
Safety Glass Colorless (Vertical Handrail Standard)

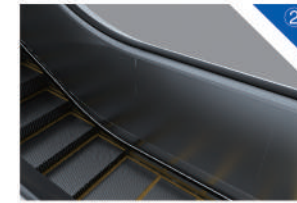

不锈钢 (斜扶手标配)
Stainless Steel (Oblique Inclined Handrail Standard)

运行方向指示灯 Running Direction Indicator

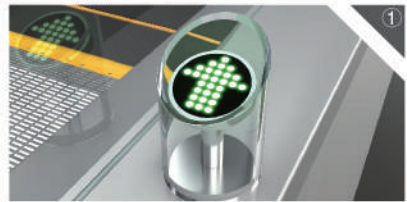

透明塑料LED显示 (选配)
Transparent Plastic LED Display (Optional)



黑色塑料点阵显示 (选配)
Black Plastic Dot Matrix Display (Optional)

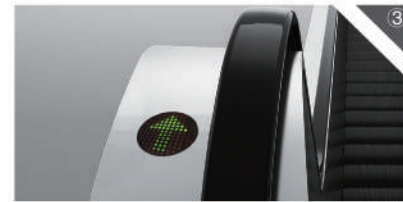

绿色箭头点阵显示 (KLT-XF 选配)
Green Arrow Dot Matrix Display (KLT-XF Optional)

前沿板 Frontier Board

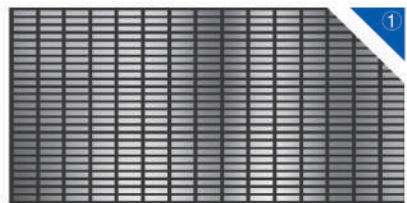

不锈钢方块贴片 (标配)
Stainless Steel Square Patch (Standard)

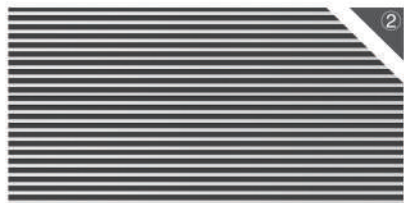

铝合金贴片 (选配)
Aluminum Patch (Optional)

注: 图片系电脑绘制, 可能与实际略有不同, 以实物为准。
Note: Pictures have been drawn by computer. It might be slightly different from actual colors. Please take real product as criterion.

土建参数

Parameter Construction Layout

KLT30-M 室内 Indoor
KLT30-60M/80M/100M

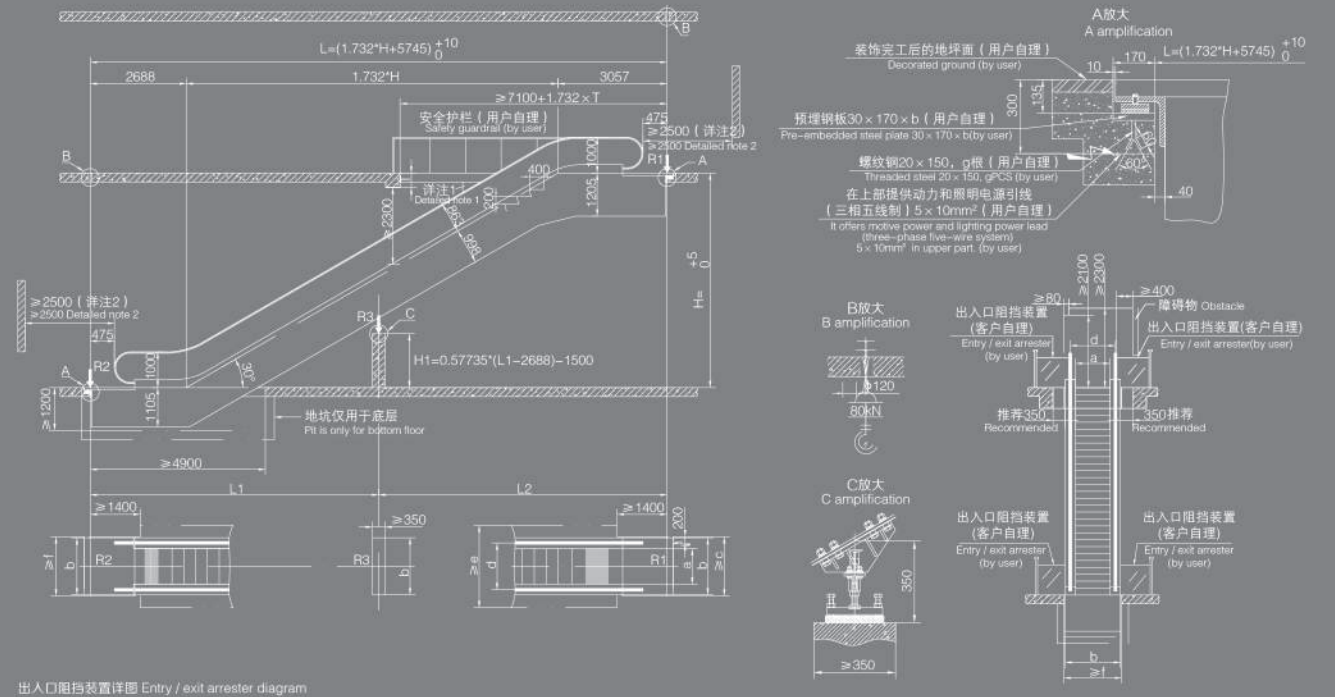

注1: 自动扶梯在与楼板交叉处在扶手上设置一个无锐角边缘的垂直防夹挡板。如果扶手带外缘与任何障碍物之间距离大于400mm时, 则无需此挡板。
Note 1: A vertical anti-pinch plate that has no acute angle edge should be set on the handrail belt in the junction between escalator and floor slab. If the distance between the outer edge of the handrail belt and any obstruction is greater than 400mm, it does not have to install the anti-pinch plate.

注2: 在自动扶梯的出入口, 应有充分畅通的区域, 以容纳乘客。如果该区域的宽度增至扶手带外缘距离加上每边各80mm的两倍及以上, 则其纵深尺寸允许减至2米。
Note 2: There should be adequate flow area to accommodate passengers at the entrance and exit of the escalator. If the width of the area is more than twice the distance between outer edge of the handrail belt plus 160mm, its depth dimension is allowed to be less than 2 meters.

标准规格及尺寸单位 (mm)

Standard specification and size Unit (mm)

梯级宽度 Step width	a	KLT-60M	600	KLT-80M	800	KLT-100M	1000
装饰宽度 Decoration width	b		1140		1340		1540
土建开口宽度 Construction layout opening width	c		1200		1400		1600
扶手间距 Handrail spacer	d		838		1038		1238
安全土建开口宽度 Safety construction layout opening width	e		1718		1918		2118
土建开口宽度 Construction layout opening width	f		1200		1400		1600
螺纹钢数量 (根) Threaded steel quantity (PCS)	g		4		5		6
运行速度 (m/s) Running speed (m/s)			0.5		0.5		0.5
倾斜角 (°) Degree of inclination (°)			30		30		30

支反力及功率

Reaction force and power

R1(kN)	梯级宽度 600	4.1×L2+15.5	梯级宽度 800	4.5×L2+16.1	梯级宽度 1000	5×L2+17.5
R2(kN)		4.1×L1+7.8		4.5×L1+7.8		5×L1+8.5
R3(kN)		4.25×L+9.5		4.5×L+10.5		5.2×L+11.5

L, L1, L2单位为m, L1, L2都不超过15m。
L, L1, L2unit is m. L1, L2 will not exceed 15m.

- #### 说明
- 本图适用于16m以下单台安装的自动扶梯土建施工之用。
 - 选用梯级宽度600mm或选用双驱动, 桁架上部必须延长550mm, 当H≤5.7m, 取消中间支撑。
 - 销售部门应将本图一式4份提供用户, 其中2份经用户盖章, 签字后返回技术科。
 - 尺寸单位为mm, 个别尺寸可能有更改, 如有更改, 恕不另行通知。

- #### Description
- This drawing is fit for the construction of 16m and below single mounted escalators.
 - It chooses step width 600mm or double-drive. Upper truss shall be extended 550mm. When H≤5.7m, intermediate support shall be canceled then.
 - The Sales Dept. needs to make four copies of this drawing. Two copies shall return to the Technical Section after being stamped and signed by the users.
 - Size unit: mm. It is possible to change some individual sizes. If there is any alterations, advance notice won't be given then.

土建参数 Parameter Construction Layout

KLT30-M 室外 Outdoor
KLT30-60M/80M/100M

KLT-XF(内置轮斜扶手) 室内 Internal Wheel Inclined Handrail (Indoor)
KLT-XF30-I-60M/80M/100M

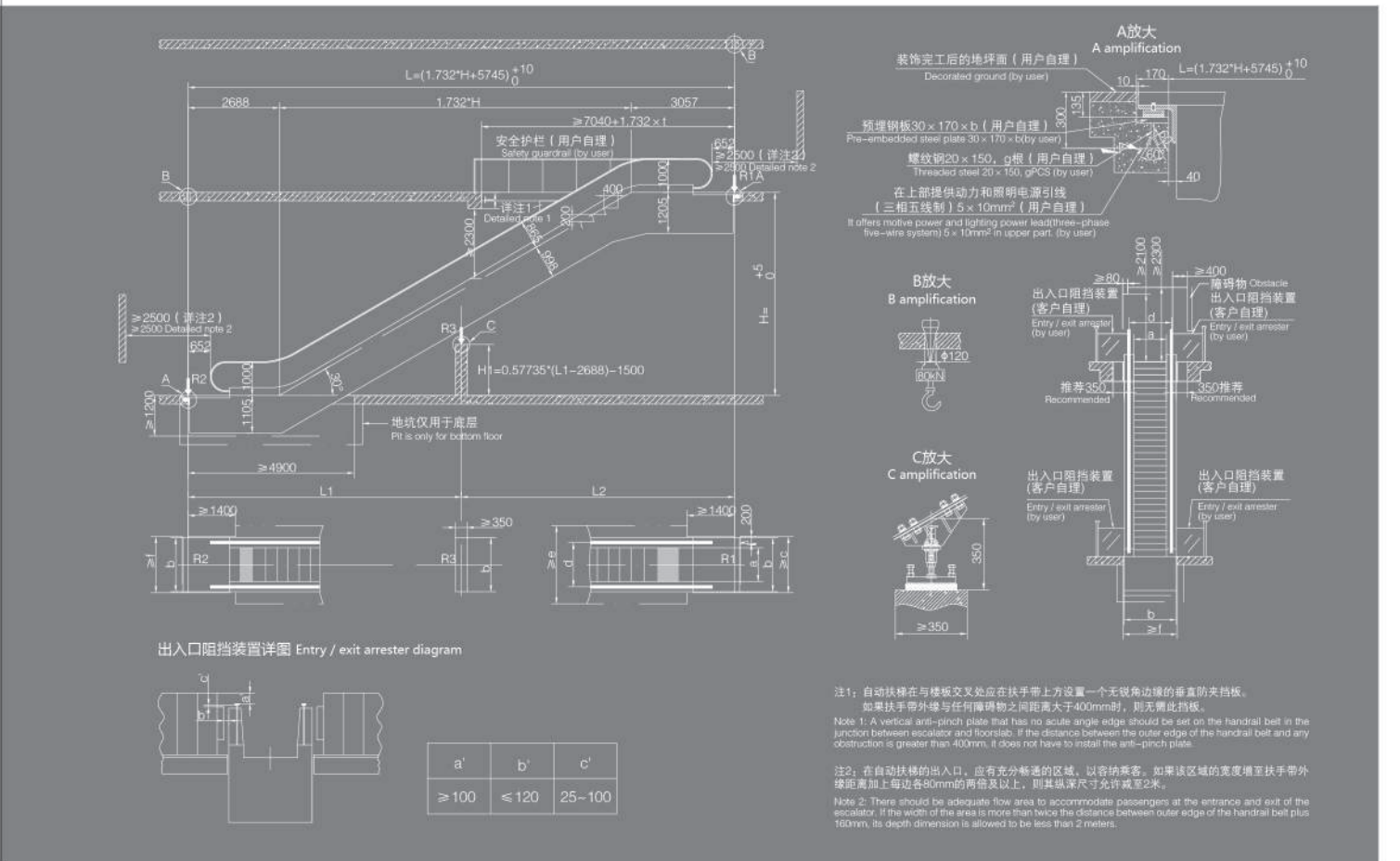
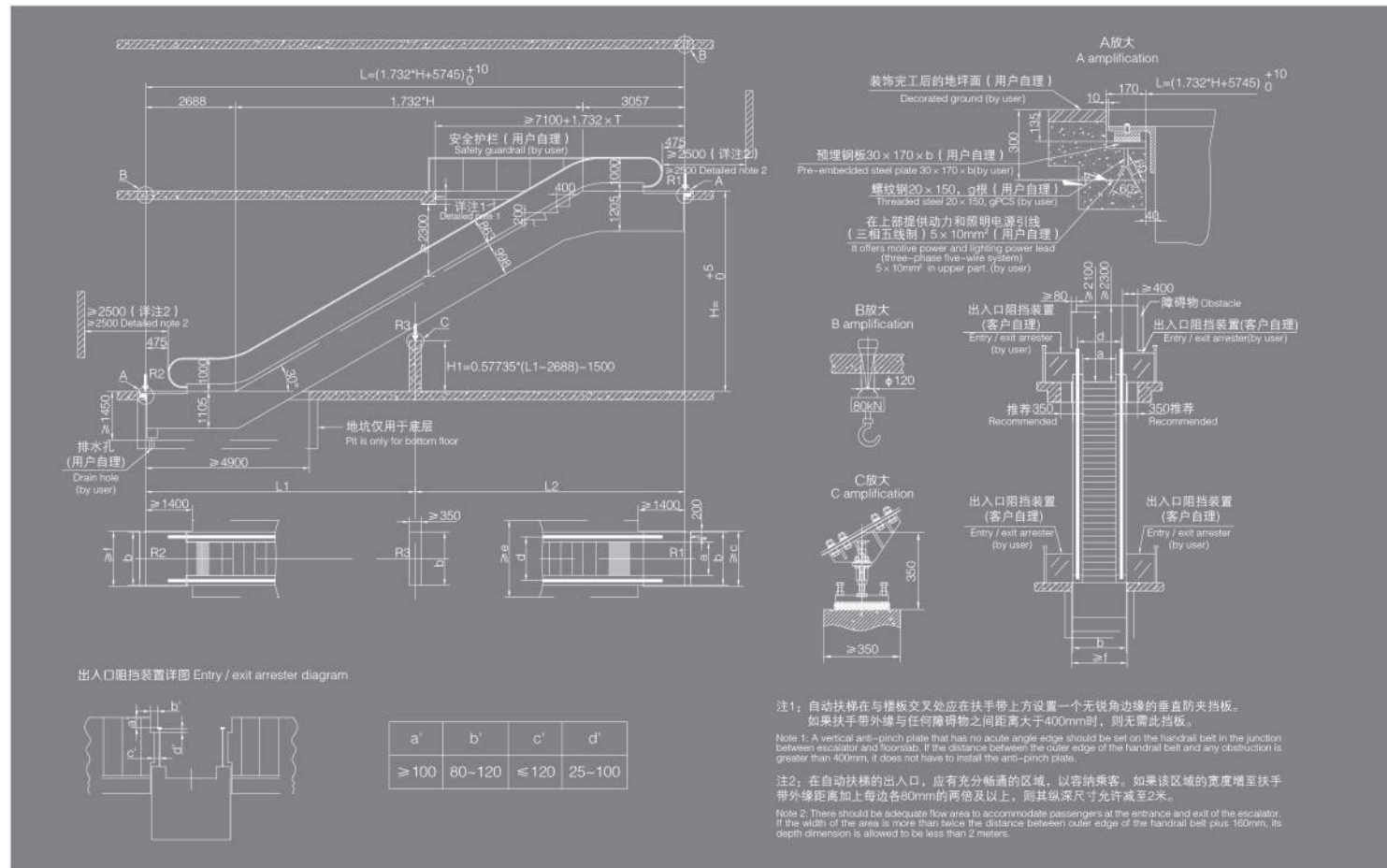

标准规格及尺寸 单位 (mm) Standard specification and size Unit (mm)

梯级宽度 Step width	a	KLT-60M 600	KLT-80M 800	KLT-100M 1000
装饰宽度 Decoration width	b	1140	1340	1540
土建开口宽度 Construction layout opening width	c	1200	1400	1600
扶手间距 Handrail spacer	d	838	1038	1238
安全土建开口宽度 Safety construction layout opening width	e	1718	1918	2118
土建开口宽度 Construction layout opening width	f	1200	1400	1600
螺纹钢数量 (根) Threaded steel quantity (PCS)	g	4	5	6
运行速度 (m/s) Running speed (m/s)		0.5	0.5	0.5
倾斜角 (°) Degree of inclination (°)		30	30	30

Description

1. This drawing is fit for the construction of 16m and below single mounted escalators.
2. It chooses step width 600mm or double-drive. Upper truss shall be extended 550mm. When H≤5.7m, intermediate support shall be canceled then.
3. The Sales Dept. needs to make four copies of this drawing. Two copies shall return to the Technical Section after being stamped and signed by the users.
4. Size unit: mm. It is possible to change some individual sizes. If there is any alterations, advance notice won't be given then.

支反力及功率 Reaction force and power

R1(kN)	梯级宽度 600 4.1×L2+15.5	梯级宽度 800 4.5×L2+16.1	梯级宽度 1000 5×L2+17.5
R2(kN)	4.1×L1+7.8	4.5×L1+7.8	5×L1+8.5
R3(kN)	4.25×L+9.5	4.5×L+10.5	5.2×L+11.5

L, L1, L2单位为m, L1, L2都不超过15m。
Unit for L, L1, L2 is m, L1, L2 will not exceed 15m.

说明

1. 本图适用于16m以下单台安装的自动扶梯土建施工之用。
2. 选用梯级宽度600mm或选用双驱动, 桁架上部必须延长550mm, 当H≤5.7m, 取消中间支撑。
3. 销售部门应将本图一式4份提供用户, 其中2份经用户盖章, 签字后返回技术科。
4. 尺寸单位为mm, 个别尺寸可能有更改, 如有更改, 恕不另行通知。

标准规格及尺寸 单位 (mm) Standard specification and size Unit (mm)

梯级宽度 Step width	a	KLT-XF-I-60M 600	KLT-XF-I-80M 800	KLT-XF-I-100M 1000
装饰宽度 Decoration width	b	1140	1340	1540
土建开口宽度 Construction layout opening width	c	1200	1400	1600
扶手间距 Handrail spacer	d	838	1038	1238
安全土建开口宽度 Safety construction layout opening width	e	1718	1918	2118
土建开口宽度 Construction layout opening width	f	1200	1400	1600
螺纹钢数量 (根) Threaded steel quantity (PCS)	g	4	5	6
运行速度 (m/s) Running speed (m/s)		0.5	0.5	0.5
倾斜角 (°) Degree of inclination (°)		30	30	30

Description

1. This drawing is fit for the construction of 16m and below single mounted escalators.
2. It chooses step width 600mm or double-drive. Upper truss shall be extended 550mm. When H≤5.7m, intermediate support shall be canceled then.
3. The Sales Dept. needs to make four copies of this drawing. Two copies shall return to the Technical Section after being stamped and signed by the users.
4. Size unit: mm. It is possible to change some individual sizes. If there is any alterations, advance notice won't be given then.

支反力及功率 Reacting force and power

R1(kN)	梯级宽度 600 4.1×L2+15.5	梯级宽度 800 4.5×L2+16.1	梯级宽度 1000 5×L2+17.5
R2(kN)	4.1×L1+7.8	4.5×L1+7.8	5×L1+8.5
R3(kN)	4.25×L+9.5	4.5×L+10.5	5.2×L+11.5

L, L1, L2单位为m, L1, L2都不超过15m。
Unit for L, L1, L2 is m, L1, L2 are less than 15m.

说明

1. 本图适用于16m以下单台安装的自动扶梯土建施工之用。
2. 选用梯级宽度600mm或选用双驱动, 桁架上部必须延长550mm, 当H≤5.7m, 取消中间支撑。
3. 销售部门应将本图一式4份提供用户, 其中2份经用户盖章, 签字后返回技术科。
4. 尺寸单位为mm, 个别尺寸可能有更改, 如有更改, 恕不另行通知。

土建参数 Parameter Construction Layout

KLT-XF(内置轮斜扶手) 室外 Internal Wheel Inclined Handrail (Outdoor)
KLT-XF30-I-60M/80M/100M

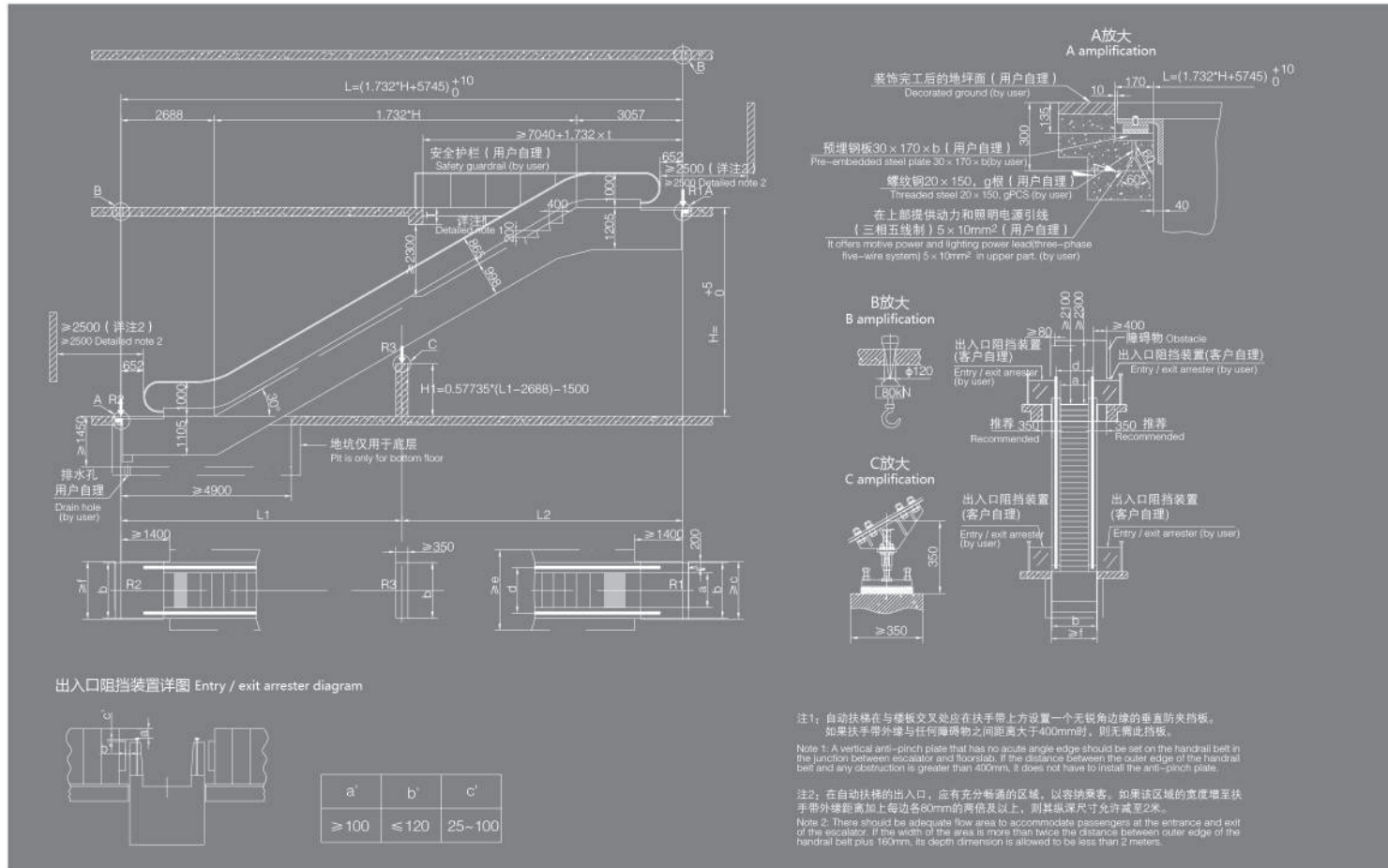

标准规格及尺寸 单位 (mm) Standard specification and size Unit (mm)

梯级宽度 Step width	a	600	800	1000
装饰宽度 Decoration width	b	1140	1340	1540
土建开口宽度 Construction layout opening width	c	1200	1400	1600
扶手间距 Handrail spacer	d	838	1038	1238
安全土建开口宽度 Safety construction layout opening width	e	1718	1918	2118
土建开口宽度 Construction layout opening width	f	1200	1400	1600
螺纹钢数量 (根) Threaded steel quantity (PCS)	g	4	5	6
运行速度 (m/s) Running speed (m/s)		0.5	0.5	0.5
倾斜角 (°) Degree of inclination (°)		30	30	30

Description

- His drawing is fit for the construction of 16m and below single mounted escalators.
- It chooses step width 600mm or double-drive. Upper truss shall be extended 550mm. When H≤5.7m, intermediate support shall be canceled then.
- The Sales Dept. needs to make four copies of this drawing. Two copies shall return to the Technical Section after being stamped and signed by the users.
- Size unit: mm. It is possible to change some individual sizes. If there is any alterations, advance notice won't be given then.

支反力及功率 Reacting force and power

R1(kN)	梯级宽度 600	4.1×L2+15.5	梯级宽度 800	4.5×L2+16.1	梯级宽度 1000	5×L2+17.5
R2(kN)	梯级宽度 600	4.1×L1+7.8	梯级宽度 800	4.5×L1+7.8	梯级宽度 1000	5×L1+8.5
R3(kN)	梯级宽度 600	4.25×L+9.5	梯级宽度 800	4.5×L+10.5	梯级宽度 1000	5.2×L+11.5

L, L1, L2单位为m, L1, L2都不超过15m。
Unit for L, L1, L2 is m, L1, L2 are less than 15m.

说明

- 本图适用于16m以下单台安装的自动扶梯土建施工之用。
- 选用梯级宽度600mm或选用双驱动, 桁架上部必须延长550mm, 当H≤5.7m, 取消中间支撑。
- 销售部门应将本图一式4份提供用户, 其中2份经用户盖章, 签字后返回技术科。
- 尺寸单位为mm, 个别尺寸可能有更改, 如有更改, 恕不另行通知。

全国分公司服务网络 National Branch Service Network

- 辽宁分公司**
销售热线: 024-31981333 传真: 024-31981222
地址: 沈阳市大东区滂江街26-1国际公寓2916
- 无锡分公司**
销售热线: 0510-85861251 传真: 0510-85861252
地址: 无锡市滨湖区梁青路58号华邸国际大厦A座1501室
- 大连分公司**
销售热线: 0411-86552277 传真: 0411-86552299
地址: 大连市中山区民康街15号报业大厦16层E
- 徐州分公司**
销售热线: 0516-83919000 传真: 0516-83919005
地址: 徐州市庆丰路绿地城市广场瀛海写字楼A座706室
- 上海分公司**
销售热线: 021-62828058/62827558 传真: 021-62828360
地址: 上海市延安西路1221号2203室
- 黑龙江分公司**
销售热线: 0451-82346098 传真: 0451-82318292
地址: 黑龙江省哈尔滨市道里区群力第四大道399号汇智广场西楼1004室
- 浙江分公司**
销售热线: 0571-89971040 传真: 0571-86590365
地址: 杭州市新塘路19号采荷嘉业5幢1204室
- 吉林分公司**
销售热线: 0431-86770000 传真: 0431-81030300
地址: 长春市经济技术开发区临河街5445号圣豪汇商705室
- 安徽分公司**
销售热线: 0551-62671797 传真: 0551-62313639
地址: 安徽省合肥市蜀山区望江西路69号西湖国际广场A座603室
- 北京分公司**
销售热线: 010-65505559 传真: 010-65505562
地址: 北京市朝阳区八里庄西里97号住邦2000商务中心4号楼10层
- 芜湖分公司**
销售热线: 0553-3856158
地址: 芜湖市镜湖区长江中路66号 徽商财富广场北楼1802室
- 内蒙古分公司**
销售热线: 0471-6289116 传真: 0471-6922767
地址: 呼和浩特市回民区新华西街明泽广场A座21层2110室
- 江西分公司**
销售热线: 0791-88223016 传真: 0791-88399056
地址: 南昌市高新开发区紫阳大道绿地新都会紫峰(幢)大厦写字楼34层3402室
- 河北分公司**
销售热线: 0311-66792031 转 8002 传真: 0311-87893130
地址: 石家庄市建设南大街29号众鑫大厦818-820室
- 湖北分公司**
销售热线: 027-82660063 传真: 027-85770699
地址: 武汉市江汉区淮海路中段泛海国际SOHO城2605-2606室
- 天津分公司**
销售热线: 022-58306090 传真: 022-58306091
地址: 天津市红桥区光荣道与保康路交口宝能创业中心B座24层2412室
- 襄阳分公司**
销售热线: 0710-3287220 传真: 0710-3287220
地址: 襄阳市高新区长虹北路万达小区1栋二单元1902室
- 山西分公司**
销售热线: 0351-8371869 传真: 0351-8371859
地址: 太原市小店区平阳路1号金茂国际数码中心A座16层F室
- 湖南分公司**
销售热线: 0731-85787755 传真: 0731-85787722
地址: 长沙市岳麓区岳麓大道57号奥克斯广场B座1127-1129
- 陕西分公司**
销售热线: 029-88332244 传真: 029-88332244-831
地址: 西安市莲湖区唐延路北段22号金辉国际广场11层
- 重庆分公司**
销售热线: 023-67877015 传真: 023-67877025
地址: 重庆市渝中区大坪正街160号万科锦程1栋26-6
- 甘肃分公司**
销售热线: 0931-8811752 传真: 0931-8432645
地址: 甘肃省兰州市城关区澳兰名门B2座708室
- 四川分公司**
销售热线: 028-61320037 传真: 028-87321179
地址: 四川省成都市高新区新世纪环球中心西区8-1-1707
- 新疆分公司**
销售热线: 0991-4815313 传真: 0991-4815795-815
地址: 新疆乌鲁木齐沙依巴克区友好北路793号高地中心1105室
- 河南分公司**
销售热线: 0371-60189221
地址: 郑州市郑东新区康平路永平路郑东商业中心写字楼一号楼17楼1707
- 山东分公司**
销售热线: 0531-55693961 传真: 0531-55693965
地址: 济南市市中区经四路13号万达广场C座办公楼2606室
- 贵州分公司**
销售热线: 0851-86515286 传真: 0851-86515286转81
地址: 贵阳市观山湖区金阳南路6号世纪城购物中心D栋写字楼23层5号
- 青岛分公司**
销售热线: 0532-68890088 传真: 0532-89092106
地址: 青岛市市北区山东路177号鲁邦广场B座1106-1107
- 广西分公司**
销售热线: 0771-5517626 传真: 0771-5505713
地址: 南宁市民族大道92-1号新城国际1401号
- 烟台分公司**
销售热线: 0535-6887005 传真: 0535-6887005
地址: 山东省烟台市莱山区银海路566号南山世纪华府13-2-2802
- 广东分公司**
销售热线: 020-38021060 传真: 020-38021410
地址: 广州市天河区天河路625号天娱广场东塔1007-1008室
- 烟台分公司**
销售热线: 0535-6887005 传真: 0535-6887005
地址: 山东省烟台市莱山区银海路566号南山世纪华府13-2-2802
- 深圳分公司**
销售热线: 0755-83865618 传真: 0755-83865618
地址: 深圳市福田区益田路3008号皇都广场A座1906室
- 南京分公司**
销售热线: 025-58812988 传真: 025-84519155-81
地址: 南京市洪武路359号福鑫大厦西2602室
- 珠海分公司**
销售热线: 0756-2260550 传真: 0756-2260695
地址: 珠海市香洲区银桦路102号6栋优特科技大厦909室
- 苏州分公司**
销售热线: 0512-65166725 传真: 0512-65166721
地址: 苏州工业园区苏虹中路225号星虹国际1幢2113室
- 福建分公司**
销售热线: 0591-88596982 传真: 0591-88594630
地址: 福州市五一中路88号平安大厦21G