



扫描二维码  
关注康力电梯门户网站  
Scan the QR code and pay attention to  
CANNY ELEVATOR Portal Website



扫描二维码  
关注康力电梯微信公众号  
Scan the QR code and pay attention to  
CANNY ELEVATOR WeChat Public Number

**KONL**® 康力电梯  
CANNY ELEVATOR

## 康力电梯股份有限公司 CANNY ELEVATOR CO.,LTD.

◎地址：江苏省汾湖高新技术产业开发区康力大道888号  
◎电话：0512-63290000  
◎传真：0512-63293938  
◎网址：www.canny-elevator.com  
◎电子信箱：(国内) marketing@canny-elevator.com  
(国外) export-canny@163.com  
export@canny-elevator.com  
◎400客户服务热线：400-188-2367  
◎邮编：215213

◎Add: No.888, Kangli Road, FOHO New & Hi-Tech Industrial  
Development Zone, Jiangsu Province, China.  
◎Tel: +86-512-63290000 63297851  
◎Fax: +86-512-63299709  
◎URL: www.canny-elevator.com  
◎E-mail: export-canny@163.com  
export@canny-elevator.com  
◎P.C: 215213

本书为一般信息类出版物，我们保留随时更改产品设计和说明的权利，所有图片和颜色可能与实物有所不同，请以实物为准。  
康力电梯股份有限公司©版权所有 2016-V1.0版



**KLW**  
无机房乘客电梯

KLW MACHINE ROOMLESS PASSENGER ELEVATOR



## KLW无机房乘客电梯

KLW MACHINE ROOMLESS PASSENGER ELEVATOR

目标市场 Target market



中高档住宅  
Residential



商务楼  
Business Building

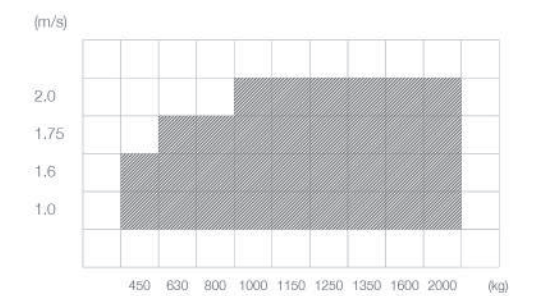

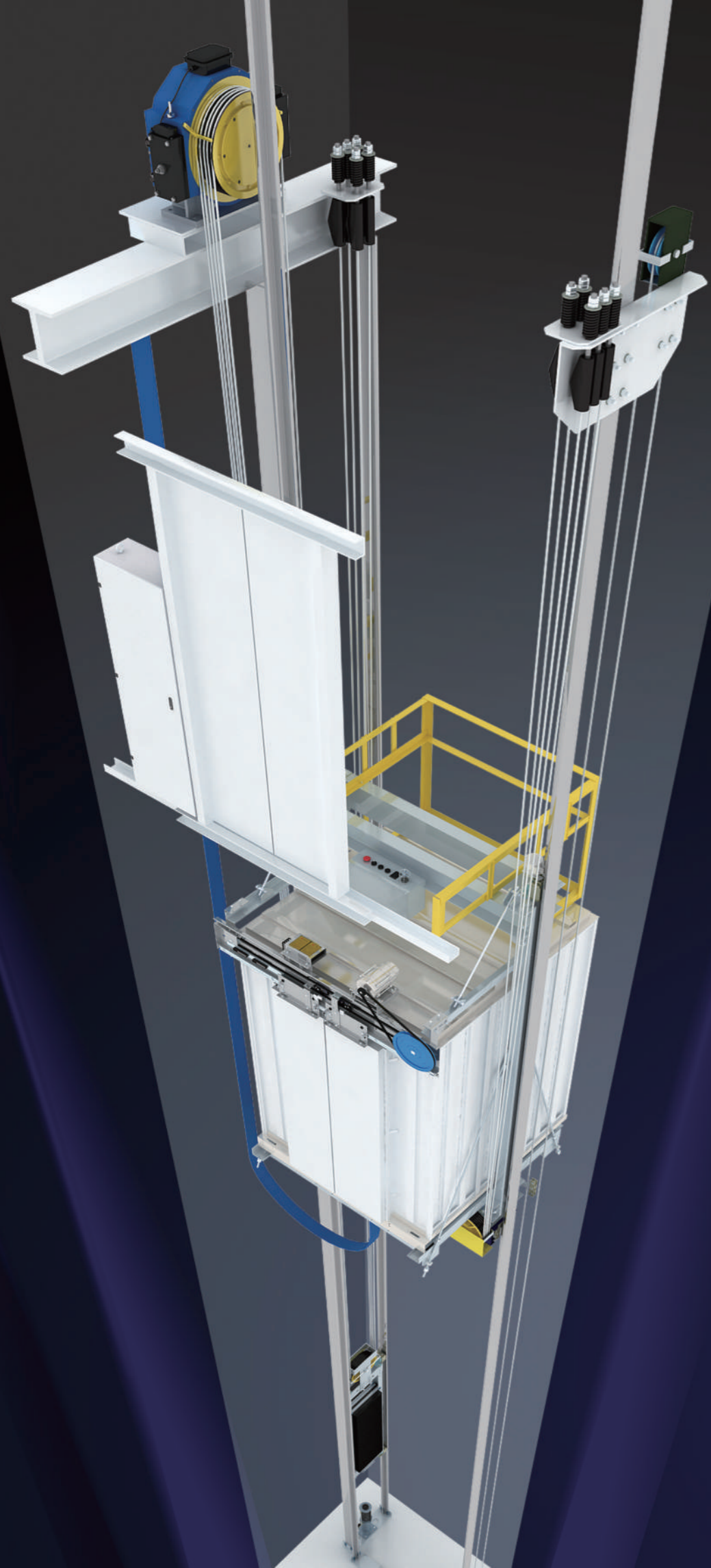

## 释放空间，创新无限

### Released space and infinite innovation

#### 一次性解除电梯多种制约

康力KLW无机房电梯系列产品，解除电梯对于建筑、建筑成本、建筑设计风格和使用范围的制约，在节约空间和节约成本的同时，为乘客带来上层智者的高效与稳健。

#### It removes the multiple elevator restrictions at one time

CANNY KLW series, machine roomless elevator removes the elevator's restrictions in construction, construction costs, architectural design style and utilization scopes. In saving space and costs, it brings passengers the efficiency and robustness of the upper wise.

各类型电梯机房比较 Comparison of various types of elevator machine room

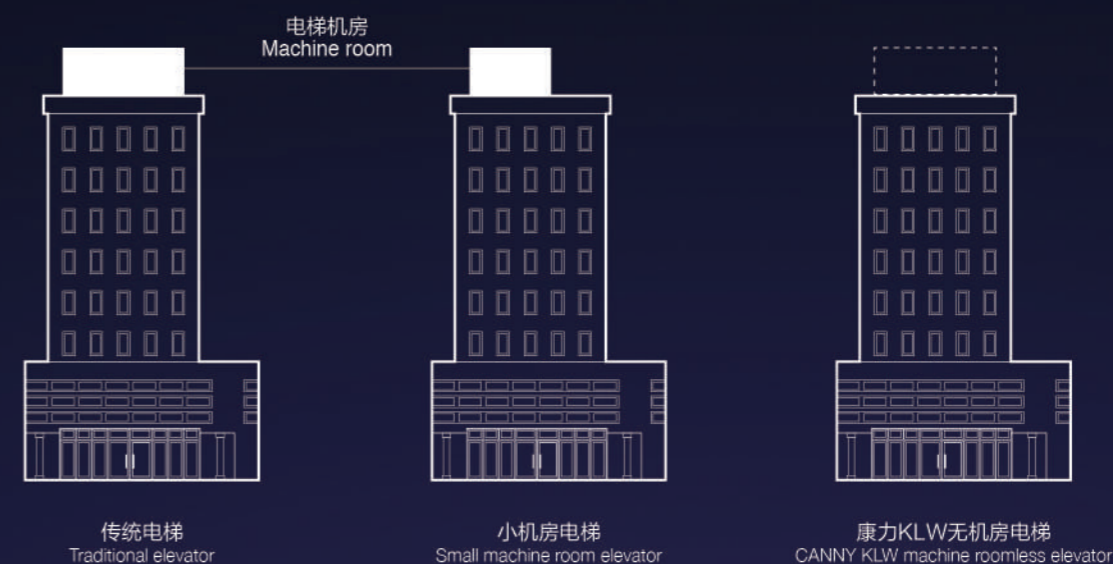

#### 节约建筑空间

康力无机房电梯将整个电梯置于井道内，解除机房对于建筑的制约，节省建筑空间。

#### Save Construction Space

CANNY machine roomless elevator puts the entire elevator into the shaft, so that the machine room can exert no limits to the construction, which can save the construction space.

#### 节约建筑成本

康力无机房电梯将控制柜放于井道内，不用额外建造机房，节省建筑成本。

#### Save construction costs

CANNY machine roomless elevator places the control cabinet in the shaft. And there is no need to build a machine room additionally, thereby saving construction costs.

#### 优化建筑设计

康力无机房电梯腾出机房空间，为楼宇的设计提供了更多的选择。

#### Optimize Construction Design

CANNY machine roomless elevator saves the space occupied by the machine room, which provides more choices for building design.

# 内蕴实力，安稳非凡

## Intrinsic strength and extraordinary stability

### 抱闸力自检测及监视功能

主动定期测试抱闸力，通过提示故障及禁止电梯运行等方式，防止更严重的事故发生。

### Brake force self-testing and monitoring function

Test the brake force periodically and autonomously to avoid more accidents by means of fault reminder and no running etc.

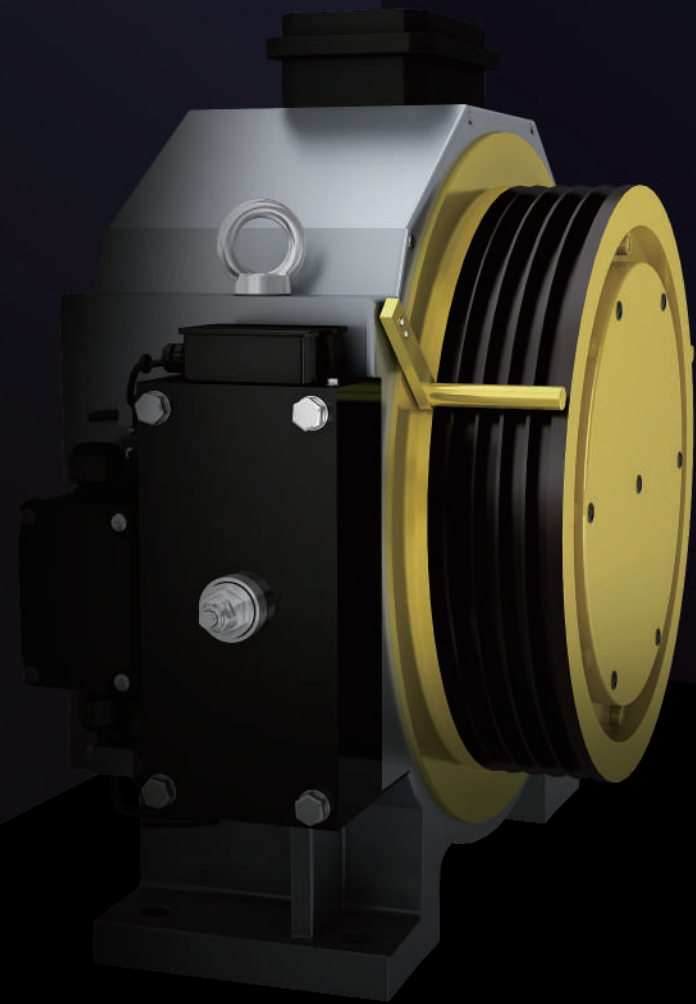
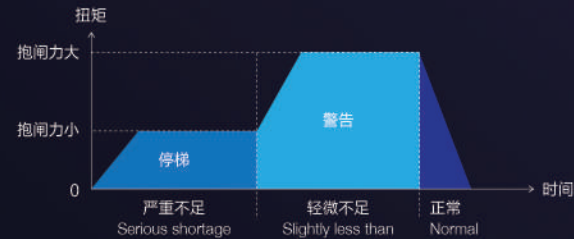

### 全新永磁门机系统

优化的S曲线，门开关平稳，电机负载冲击变小，自适应控制能力好，可应对各种干扰因素自检、自适、自调，超大聚氨酯滚轮，耐磨损能力强，实现静音运行。

### New permanent magnetic door machine system

The optimized S-curve, smooth door switch, smaller motor load shock, good self-adaptive control capability can cope with various disturbing factors and realize automatic test, adjust and adapt. The oversized polyurethane rollers have strong abrasion resistance and can achieve muting operation.

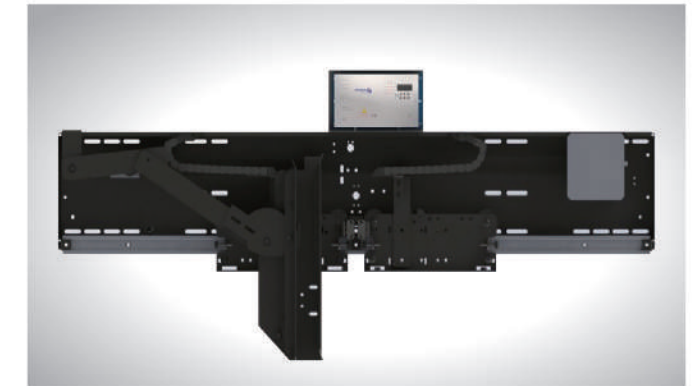

### 新一代VVVF变频器

新一代VVVF变频器，可根据轿厢负载，调整电流大小和相位，精确控制主机转动力矩，确保电梯稳健运行。

### A new generation VVVF frequency inverter

A new generation VVVF frequency inverter can adjust the current magnitude and phase according to car load and precisely control the host rotating torque to ensure the stable operation of the elevator.

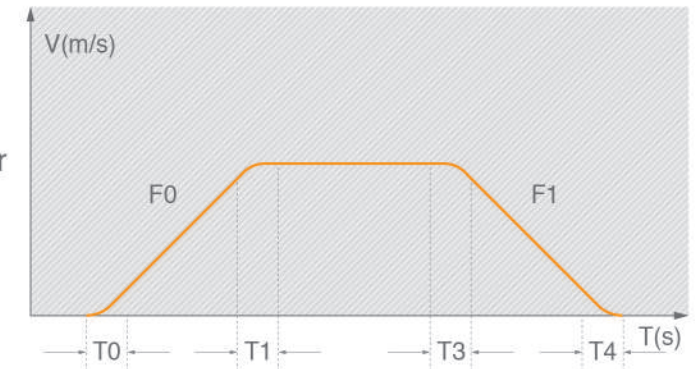

### 控制柜内置

控制柜置于井道内部，去除了建筑预留孔位，安装更加方便；同时有效避免了机房噪音污染。

### Inbuilt control cabinet

The control cabinet is placed inside the shaft, so that building reserved holes are removed and the installation will be more convenient; meanwhile, the noise pollution of the machine room can be avoided effectively.

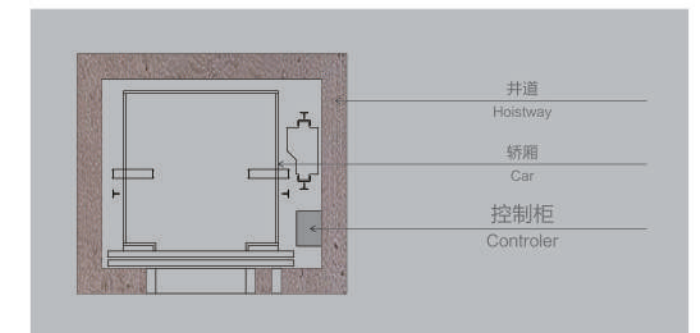

### 曳引绳滑动检测

曳引绳滑动检测，能够实时监测滑动数据并且根据需要自动进入应急减速的安全运行模式，使电梯不会因此发生事故。

### Traction rope sliding detection

Traction rope sliding detection can conduct a real-time monitoring over the data and automatically enter the safe operation mode as required to respond to the emergency by slowing down, so that the elevator accident will not happen.

### 电动松闸开关

康力无机房电梯特别配置了电动松闸开关，使紧急救援时更加及时便捷。

### Electric brake release switch

CANNY machine roomless elevator is specially equipped with the electric brake release switch so that the emergency relief can be more timely and conveniently.

# 蓄势节能，承载未来

Anticipation, energy conservation and bearing the future

## 新一代永磁同步无齿轮曳引机

新一代永磁同步无齿轮曳引机，实现强效节能40%以上，免维护，无需更换油脂，噪音小。

A new generation permanent magnet synchronous gearless traction machine

A new generation permanent magnet synchronous gearless traction machine can save more than 40% of the energy and it is maintenance-free. There is less noise and without need to replace grease.

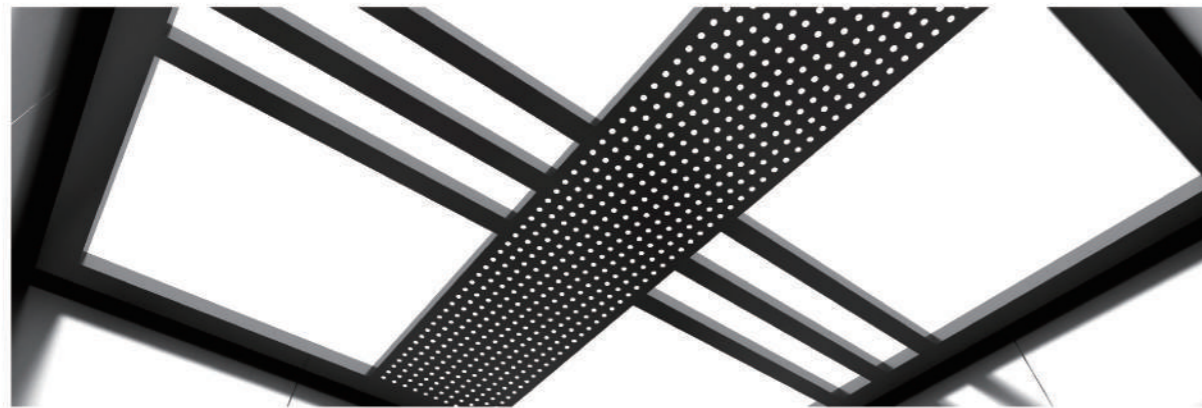
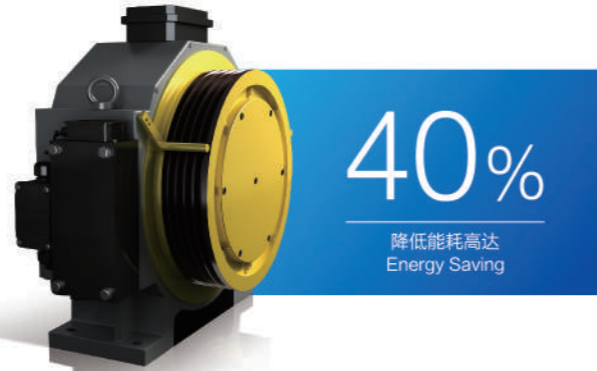

## LED轿厢照明

LED轿厢内照明装置，具有安全、高效、无辐射、易维护等优势。

LED car lighting

LED car lighting device has the advantages such as safety, efficiency, no-radiation, easy maintenance etc.



## 休眠节能程序

无人唤梯时，启动休眠节能程序，当有乘客召唤时，设备将自动启动，从而节省电梯非运行时间消耗的能源。

Dormancy energy saving procedures

In case of no callings, the elevator will start the dormancy energy saving procedures; When there's passenger call, the device will automatically start so as to save the energy consumption during the non-operational period.

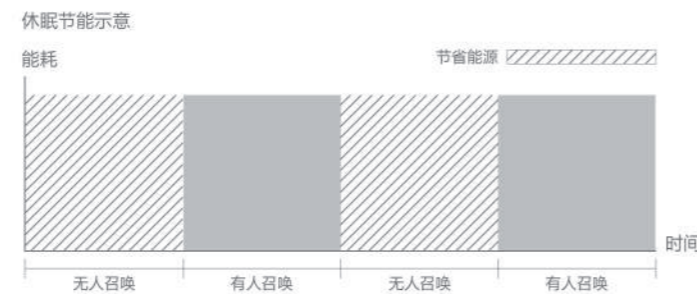

# 尊崇之道，随心而选

Road of respect, follow your heart



## IC卡智能管理系统(选配)

### 轿厢内IC卡智能设置系统

采用IC卡智能识别系统，乘客进入轿厢内便可实现刷卡到户的快捷之旅。

### IC card intelligent management system(Optional)

#### IC card intelligentsystem inside the lift car

Equipped with IC card intelligent identification system; the passenger can enjoy convenient travelling experience by swiping card and reaching the destination.

- 1.呼梯
- 2.入口楼层读取
- 3.轿内选择权限楼层
- 4.进入轿厢

- 1. Call
- 2. Read card at entrance floor
- 3. Select Floor No. in the elevator car
- 4. Enter the elevator car

Each floor can be selected for leveling, without pressing any button, it will automatically reach the designated floor of user.

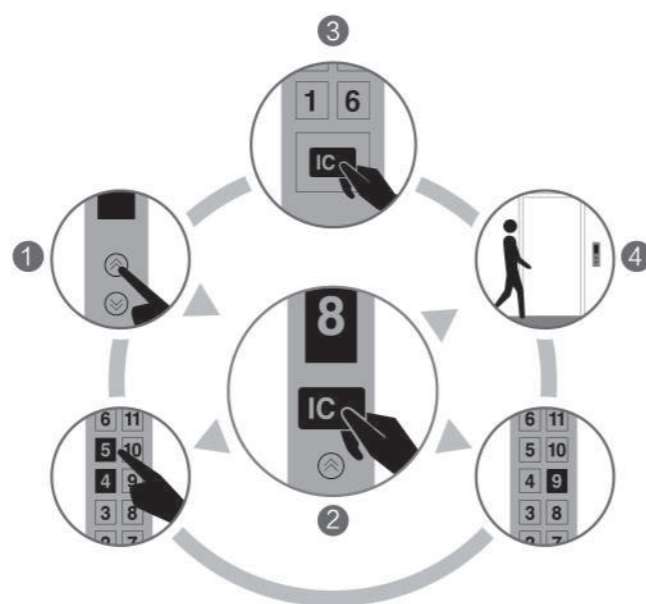

## 停电应急平层功能(选配)

电网停电后由电梯自动应急平层装置供电运行至最近层站平层开门。

### Leveling for power failure (Optional)

When the power grid powers off, the leveling device for powerfailure will power it to the nearest floor so that the door opens.



## 群控智能派梯系统(选配)

运用智能分散待梯原则，以最快速度、最高效率运载乘客。

### Group controlling intelligent dispatching system (Optional)

Abiding by the principle of intelligent dispersed principle, carry passengers with highest speed and efficiency.

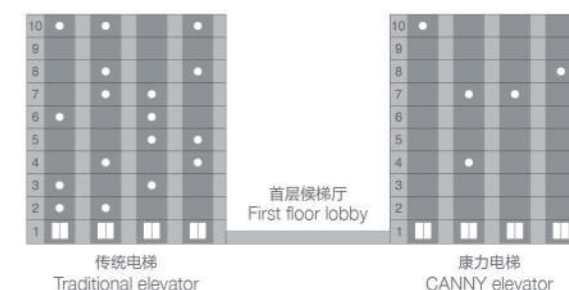

## “赛能”能量回馈再生技术(选配)

将再生能源转化成电能回馈给局域网使用，能耗降低30%。

### “Saineng” Energy renewable and feedback technology (Optional)

Transfer the renewable energy into the electric energy and return it to the local power grid for utilization, which reduces 30% of energy consumption.

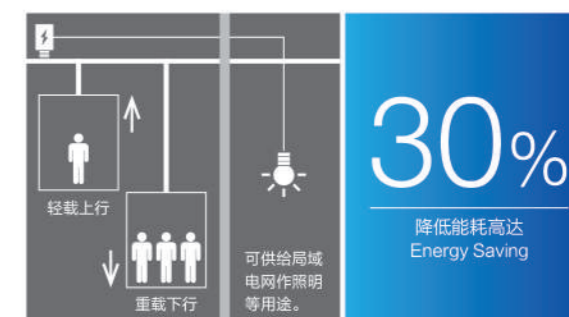

## 其它可选功能 OTHER OPTIONAL FUNCTION

**远程监控**  
Long-distance monitor

**提前开门功能**  
Pre-open Function

**BAS楼宇监控**  
Building automation system

**防捣乱功能**  
Anti-disturbance Function

# 标准型设计 Standard design



一体式操纵箱  
Integrated operation panel

## 王者风范 KL/K4-2001 (标准配置 Standard configuration)

<b>吊顶:</b>	KL/DD-4004, 喷粉钢板, 中撑小圆孔, LED光源	Ceiling: KL/DD-4004, Dusting steel plate, hole on center support, LED light source
<b>轿壁:</b>	发纹不锈钢	Car wall: Hairline stainless steel
<b>前壁:</b>	发纹不锈钢	Front wall: Hairline stainless steel
<b>立柱:</b>	发纹不锈钢	Vertical column: Hairline stainless steel
<b>操纵壁:</b>	KL231C一体式操纵箱, 发纹不锈钢	Operation panel: KL231C
<b>轿门:</b>	发纹不锈钢	Car door: Hairline stainless steel
<b>地板:</b>	KL/JD-4004 (PVC)	Floor: KL/JD-4004 (PVC)
<b>踢脚线:</b>	发纹不锈钢	Skirting: Hairline stainless steel



扫描二维码360度了解轿厢  
Scan the QR code to know more about the lift car in the 360-degree manner

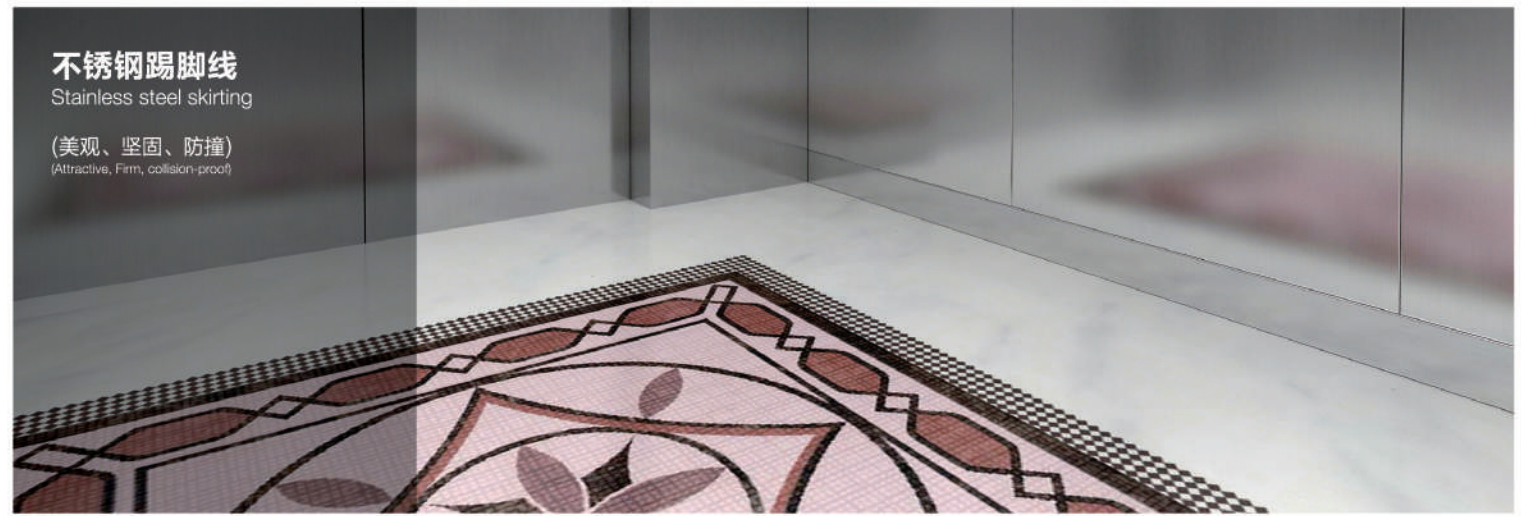

不锈钢踢脚线  
Stainless steel skirting  
(美观、坚固、防撞)  
(Attractive, Firm, collision-proof)

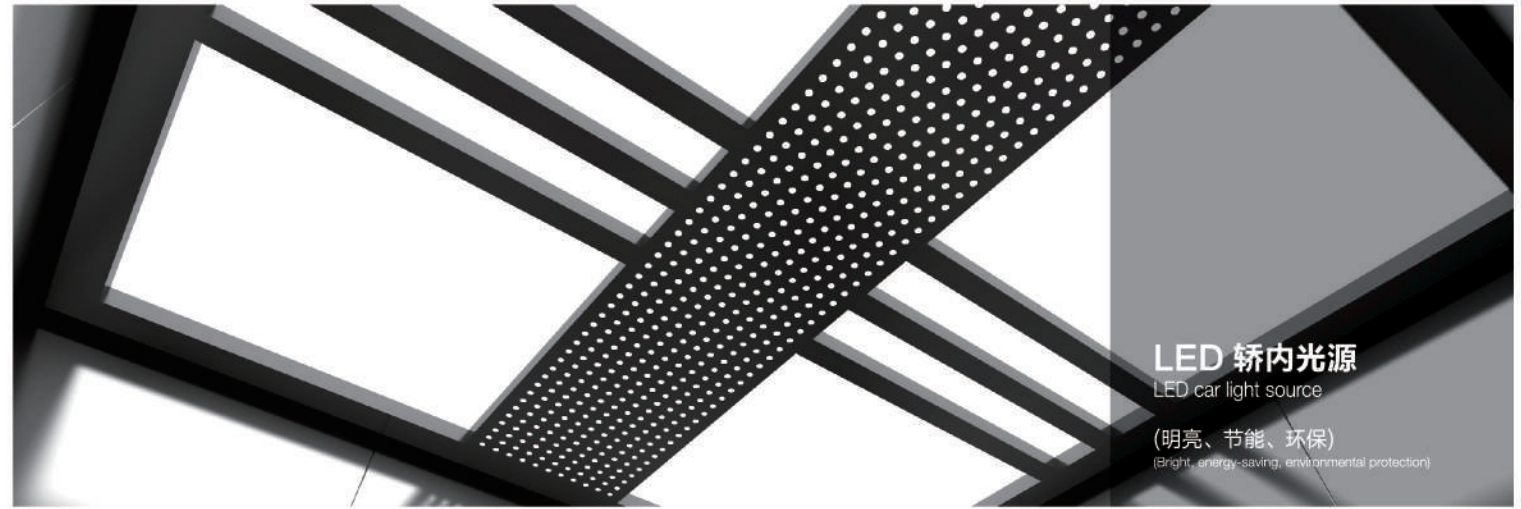

LED 轿内光源  
LED car light source  
(明亮、节能、环保)  
(Bright, energy-saving, environmental protection)



不锈钢包边立柱  
Stainless steel edging vertical column  
(美观、结实、防撞)  
(Attractive, firm and solid, collision-proof)



一体式操纵箱  
Integrated operation panel  
(美观、结实、易维护)  
(Attractive, firm and solid, Easy maintenance)

# 选配轿厢 Optional cars

更多选配设计详见康力《电梯秀》 More optional designs please see CANNY"Elevator Show"



## 友谊长存

### KL/K4-2002

有偿选配 Charged optional

- 吊顶:** KL/DD-4005, 喷粉钢板, 亚克力, LED光源
- 轿壁:** 中间: 钛金镜面蚀刻  
两侧: 贴塑钢板
- 前壁:** 钛金发纹不锈钢
- 立柱:** 钛金发纹不锈钢
- 操纵壁:** KL231C一体式操纵箱, 钛金发纹不锈钢
- 轿门:** 钛金发纹不锈钢
- 地板:** KL/JD-4005 (PVC)
- 踢脚线:** 钛金发纹不锈钢

Ceiling: KL/DD-4005, Dusting steel plate, acrylic, LED light source  
 Car wall: Middle: Titanium gold mirror etched  
 Both side: Model steel placed  
 Front wall: Titanium gold hairline stainless steel  
 Vertical column: Titanium gold hairline stainless steel  
 Operation panel: KL231C  
 Car door: Titanium gold hairline stainless steel  
 Floor: KL/JD-4005 (PVC)  
 Skirting: Titanium gold hairline stainless steel

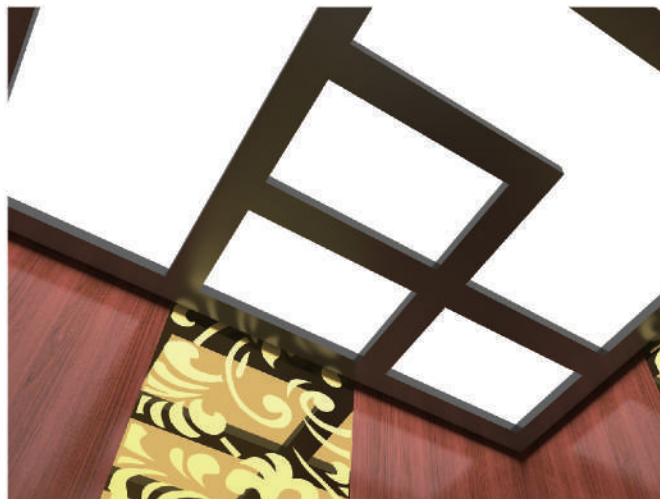
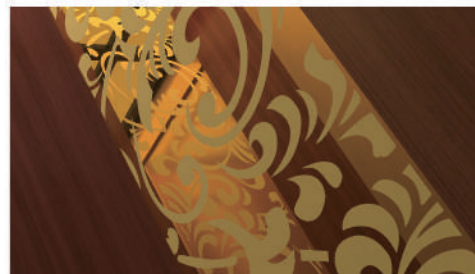

扫描二维码360度了解轿厢  
 Scan the QR code to know more  
 about the lift car in the 360-degree manner

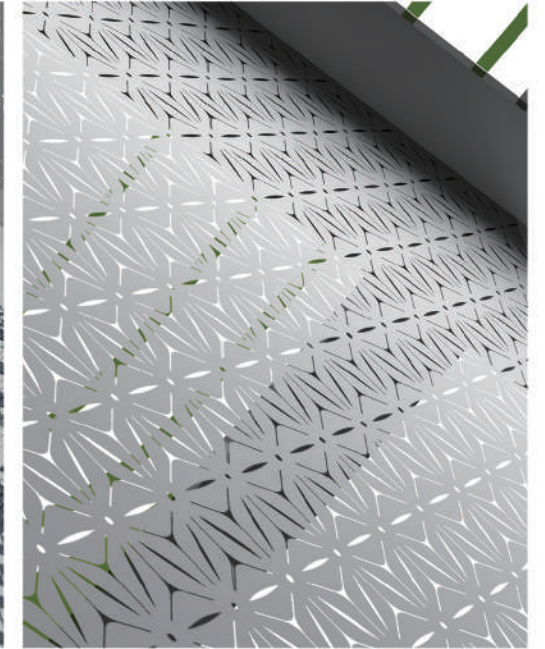
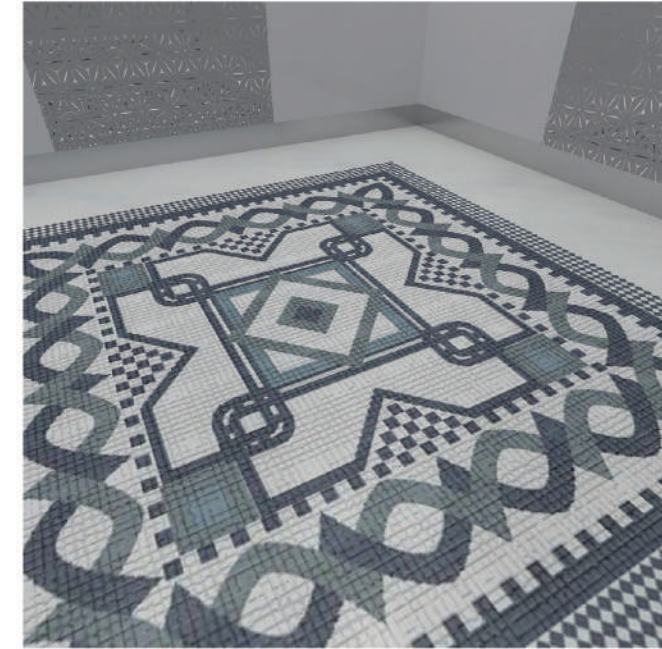

## 林海雪原

### KL/K4-2003

有偿选配 Charged optional

- 吊顶:** KL/DD-4006, 喷粉钢板, 亚克力, LED光源
- 轿壁:** 中间: 镜面蚀刻  
两侧: 贴塑钢板
- 前壁:** 镜面不锈钢
- 立柱:** 镜面不锈钢
- 操纵壁:** KL241C一体式操纵箱, 镜面不锈钢
- 轿门:** 镜面不锈钢
- 地板:** KL/JD-4006 (PVC)
- 踢脚线:** 发纹不锈钢

Ceiling: KL/DD-4006, Dusting steel plate, acrylic, LED light source  
 Car wall: Middle: Mirror etched  
 Both side: Model steel placed  
 Front wall: Mirror stainless steel  
 Vertical column: Mirror stainless steel  
 Operation panel: KL241C  
 Car door: Mirror stainless steel  
 Floor: KL/JD-4006 (PVC)  
 Skirting: Hairline stainless steel

扫描二维码360度了解轿厢  
 Scan the QR code to know more  
 about the lift car in the 360-degree manner





## 一体式操纵盘 Integrated operation panel

康力KLW无机房乘客电梯，采用造型上最简洁的一体式操纵盘，无需再次安装，造型天然，用料环保，节省成本，反应灵敏，易维护。

Stanozolol KLW no room passenger elevator, using the shape of the most simple one-piece dashboard, without having to install again, modeling natural, environmentally friendly materials, cost, responsive, and easy to maintain.



扫描二维码360度了解轿厢  
Scan the QR code to know more  
about the lift car in the 360-degree manner



扫描二维码360度了解轿厢  
Scan the QR code to know more  
about the lift car in the 360-degree manner



扫描二维码360度了解轿厢  
Scan the QR code to know more  
about the lift car in the 360-degree manner

### KL-K 001

无偿选配 Free optional

**吊顶:** KL-D 001, LED光源  
**轿壁:** 发纹不锈钢  
**前壁:** 发纹不锈钢  
**立柱:** 发纹不锈钢  
**操纵壁:** KL231C一体式操纵箱, 发纹不锈钢  
**轿门:** 发纹不锈钢  
**地板:** KL-JD 009 (PVC)  
**踢脚线:** 发纹不锈钢

Ceiling: KL-D 001, LED car light source  
Car wall: Hairline stainless steel  
Front wall: Hairline stainless steel  
Vertical column: Hairline stainless steel  
Operation panel: KL231C  
Car door: Hairline stainless steel  
Floor: KL-JD 009(PVC)  
Skirting: Hairline stainless steel

### KL-K 003

有偿选配 Charged optional

**吊顶:** KL-D 002, LED光源  
**轿壁:** 发纹不锈钢, 镜面, 蚀刻  
**前壁:** 发纹不锈钢  
**立柱:** 发纹不锈钢  
**操纵壁:** KL231C一体式操纵箱, 发纹不锈钢  
**轿门:** 发纹不锈钢  
**地板:** KL-JD 006 (PVC拼花)  
**踢脚线:** 发纹不锈钢  
**扶手:** KL-FS 001

Ceiling: KL-D 002, LED car light source  
Car wall: Hairline stainless steel  
mirror, etched  
Front wall: Hairline stainless steel  
Vertical column: Hairline stainless steel  
Operation panel: KL231C  
Car door: Hairline stainless steel  
Floor: KL-JD 006(PVC parquet)  
Skirting: Hairline stainless steel  
Handrail: KL-FS 001

### KL-K 004

有偿选配 Charged optional

**吊顶:** KL-D 006, LED光源  
**轿壁:** 发纹不锈钢, 横蚀刻  
**前壁:** 发纹不锈钢  
**立柱:** 发纹不锈钢  
**操纵壁:** KL231C一体式操纵箱, 发纹不锈钢  
**轿门:** 发纹不锈钢  
**地板:** KL-JD 005 (PVC拼花)  
**踢脚线:** 发纹不锈钢  
**扶手:** KL-FS 003

Ceiling: KL-D 006, LED car light source  
Car wall: Hairline stainless steel,  
sideways etching  
Front wall: Hairline stainless steel  
Vertical column: Hairline stainless steel  
Operation panel: KL231C  
Car door: Hairline stainless steel  
Floor: KL-JD 005(PVC parquet)  
Skirting: Hairline stainless steel  
Handrail: KL-FS 003



**显示屏**  
点阵显示屏  
Dot matrix display  
**停层数**  
2-48停层  
2-48 stop layer



面板材质(发纹不锈钢)  
Panel material (Hairline stainless steel)

**可选按钮**  
Button optional



KL231C  
标配  
Stanard



KL232C  
无偿选配  
Free optional



面板材质(镜面不锈钢)  
Panel material (Mirror stainless steel)

**可选按钮**  
Button optional



KL241C  
有偿选配  
Charged optional



KL242C  
有偿选配  
Charged optional

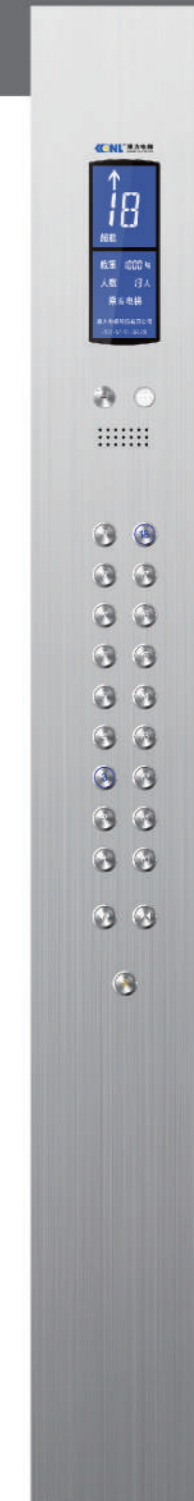

**显示屏**  
液晶显示屏  
Liquid crystal display screen  
**停层数**  
2-48停层  
2-48 stop layer



面板材质(发纹不锈钢)  
Panel material (Hairline stainless steel)

**可选按钮**  
Button optional



KL233C  
有偿选配  
Charged optional



KL234C  
有偿选配  
Charged optional



面板材质(镜面不锈钢)  
Panel material (Mirror stainless steel)

**可选按钮**  
Button optional



KL243C  
有偿选配  
Charged optional



KL244C  
有偿选配  
Charged optional

## 嵌入式操纵盘 Embedded operating panels

康力嵌入式操纵盘，满足多样化操纵功能定制，结构更坚固，维护更方便。

The embedded operating panel meets the customization of the diversified control functions, thus making the structure more solid and the maintenance more convenient.

### 一体式操纵盘 Integrated operation panel

**显示屏** Display screen  
多媒体显示屏 Multimedia display screen  
**停层数** Parking number  
2-48停层 2-48 stop layer

面板材质(发纹不锈钢)  
Panel material (Hairline stainless steel)

**可选按钮** Button optional  
**可选屏幕尺寸** Optional screen size



面板材质(镜面不锈钢)  
Panel material (Mirror stainless steel)

**可选按钮** Button optional  
**可选屏幕尺寸** Optional screen size



**显示屏** Display screen  
点阵显示屏 Dot matrix display screen  
**停层数** Parking number  
2-48停层 2-48 stop layer

面板材质(发纹不锈钢)  
Panel material (Hairline stainless steel)

**可选按钮** Button optional



面板材质(镜面不锈钢)  
Panel material (Mirror stainless steel)

**可选按钮** Button optional



**轿内横显** Display screen  
点阵显示屏 Dot matrix display screen  
**停层数** Parking number  
2-48停层 2-48 stop layer

**轿内横显** Car indicator

**可选按钮** Button optional



面板材质(发纹不锈钢)  
Panel material (Hairline stainless steel)  
**KL265C** 无偿选配 Free optional  
**KL266C** 无偿选配 Free optional

面板材质(镜面不锈钢)  
Panel material (Mirror stainless steel)  
**KL275C** 有偿选配 Charged optional  
**KL276C** 有偿选配 Charged optional

**轿内横显** Car indicator

**可选按钮** Button optional



面板材质(发纹不锈钢)  
Panel material (Hairline stainless steel)  
**KL267C** 有偿选配 Charged optional  
**KL268C** 有偿选配 Charged optional

面板材质(镜面不锈钢)  
Panel material (Mirror stainless steel)  
**KL277C** 有偿选配 Charged optional  
**KL278C** 有偿选配 Charged optional

# 无底盒召唤指示器 Calling indicator without bottom box

打破传统召唤盒安装在墙面打洞的模式，无需土建留孔，结构紧凑，拆卸方便，维保迅捷。

Need to break the traditional call boxes installed in the wall holes mode without leaving holes civil, compact, easy disassembly, repair and maintenance quick.



## 单梯 Single elevator

<p><b>KL631H</b> 标配 Standard 点阵显示 Dot matrix display</p> <p><b>KL632H</b> 无偿选配 Free optional 点阵显示 Dot matrix display</p>	<p><b>KL633H</b> 有偿选配 Charged optional 液晶显示 Liquid crystal display</p> <p><b>KL634H</b> 有偿选配 Charged optional 液晶显示 Liquid crystal display</p>
--	---

## 安装方式对比 Installation methods comparison

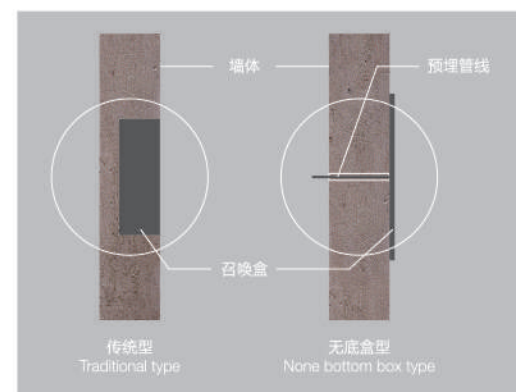

传统型：土建时需预先留孔，耗时耗力。  
无底盒型：只需预埋管线，无需土建留孔，安装维修更便捷。  
Conventional: When leaving holes to be pre-civil, time-consuming and labor-intensive.  
Bottomless box type: simply embedded pipeline, without leaving holes civil engineering, installation and maintenance more convenient.

## 可选面板材质 Panel material optional

<p>面板材质(发纹不锈钢) Panel material (Hairline stainless steel)</p> 	<p>面板材质(镜面不锈钢) Panel material (Mirror stainless steel)</p> 
--	--

## 双梯 Double-elevator

<p><b>KL635H</b> 有偿选配 Charged optional 点阵显示 Dot matrix display</p> <p><b>KL636H</b> 有偿选配 Charged optional 点阵显示 Dot matrix display</p>	<p><b>KL637H</b> 有偿选配 Charged optional 液晶显示 Liquid crystal display</p> <p><b>KL638H</b> 有偿选配 Charged optional 液晶显示 Liquid crystal display</p>
---	---

## 无底盒消防盒与锁梯盒 Fire Protection Box and Elevator Locking Box without Bottom Case

		
<b>KL651H</b> 标配 Standard	<b>KL652H</b> 标配 Standard	<b>KL653H</b> 有偿选配 Charged optional

## 可选面板材质 Panel material optional

<p>面板材质(发纹不锈钢) Panel material (Hairline stainless steel)</p> 	<p>面板材质(镜面不锈钢) Panel material (Mirror stainless steel)</p> 
--	--

## 可选面板材质 Panel material optional

<p>面板材质(发纹不锈钢) Panel material (Hairline stainless steel)</p> 	<p>面板材质(镜面不锈钢) Panel material (Mirror stainless steel)</p> 
---	--

## 残疾人操纵盘 Operation panel for disabled



			
<b>KL381CD</b> 有偿选配 Charged optional	<b>KL382CD</b> 有偿选配 Charged optional	<b>KL383CD</b> 有偿选配 Charged optional	<b>KL384CD</b> 有偿选配 Charged optional

## 可选面板材质 Panel material optional

<p>面板材质(发纹不锈钢) Panel material (Hairline stainless steel)</p> 	<p>面板材质(镜面不锈钢) Panel material (Mirror stainless steel)</p> 
--	--

## 层站横式指示器(无到站灯)有偿选配 Horizontal indicator for landing (without arrival lamp) Charged optional

			显示屏可选尺寸 Optional screen size
面板材质(发纹不锈钢) Panel material (Hairline stainless steel)	面板材质(发纹不锈钢) Panel material (Hairline stainless steel)	面板材质(发纹不锈钢) Panel material (Hairline stainless steel)	  
<b>KL341H</b> 面板材质(镜面不锈钢) Panel material (Mirror stainless steel)	<b>KL342H</b> 面板材质(镜面不锈钢) Panel material (Mirror stainless steel)	<b>KL343H</b> <b>KL344H</b> <b>KL345H</b> 面板材质(镜面不锈钢) Panel material (Mirror stainless steel)	
<b>KL351H</b>	<b>KL352H</b>	<b>KL353H</b> <b>KL354H</b> <b>KL355H</b>	

## 层站横式指示器(带到站灯)有偿选配 Horizontal indicator for landing (with arrival lamp) Charged optional

	
<b>KL365H</b> 面板材质(发纹不锈钢) Panel material (Hairline stainless steel)	<b>KL366H</b> 面板材质(发纹不锈钢) Panel material (Hairline stainless steel)
<b>KL375H</b> 面板材质(镜面不锈钢) Panel material (Mirror stainless steel)	<b>KL376H</b> 面板材质(镜面不锈钢) Panel material (Mirror stainless steel)

# 吊顶 Ceilings

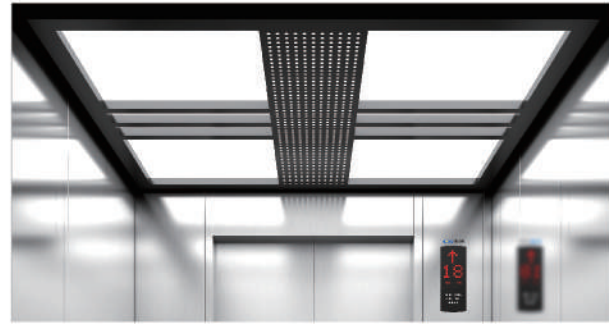

**KL / DD-4004**  
标配 Standard

喷粉钢板, 中撑小圆孔, LED光源。  
Dusting steel plate, hole on center support, LED light source.



**KL / DD-4005**  
可选 Optional

喷粉钢板, 亚克力, LED光源。  
Dusting steel plate, hole on center support, LED light source.

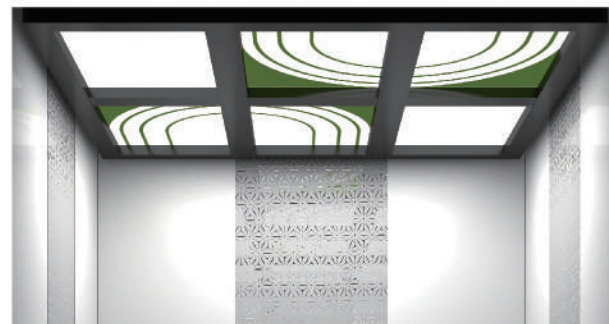

**KL / DD-4006**  
可选 Optional

喷粉钢板, 亚克力, LED光源。  
Dusting steel plate, hole on center support, LED light source.



**KL-D 001**  
可选 Optional

双拱形白色有机透光版, 中部LED灯的柔光照明设计  
Double arched white organic light emitting board plus the gentle light illumination of the mid down light.



**KL-D 002**  
可选 Optional

发纹不锈钢框架, 亚克力灯饰板(井字格), LED光源设计, 亚克力条形灯饰。  
Hairline finished st./st. frame, LED light source design, Acrylic top panel, checked.



**KL-D 006**  
可选 Optional

发纹不锈钢框架, LED光源设计, 拱形顶板加条形灯饰。  
Hairline finished st./st. frame, LED light source design, Acrylic lighting cover.

## 喷粉色标(可选) Dusting color standard (optional)

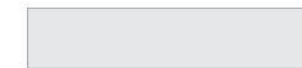

**KL-SK 001**  
冰灰 Ice gray



**KL-SK 002**  
飞机灰 Plane gray

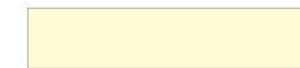

**KL-SK 003**  
米黄 Corny yellow



**KL-SK 004**  
卵石灰 Pebble gray



**KL-SK 005**  
群青蓝 Ultramarine blue



**KL-SK 006**  
松蓝蓝色 Pastel blue



**KL-SK 007**  
浅绿色 Light green



**KL-SK 008**  
淡粉红色 Light pink

## 不锈钢色标(可选) Stainless steel color standard (optional)



SUS304发纹不锈钢  
Hairline stainless steel



SUS304镜面不锈钢  
Mirror stainless steel



SUS304发纹蚀刻不锈钢  
Stainless steel etched hairline



SUS304镜面蚀刻不锈钢  
Stainless steel etched mirror



SUS304钛金发纹不锈钢  
Stainless steel titanium gold hairline



SUS304钛金镜面不锈钢  
Stainless steel titanium gold mirror

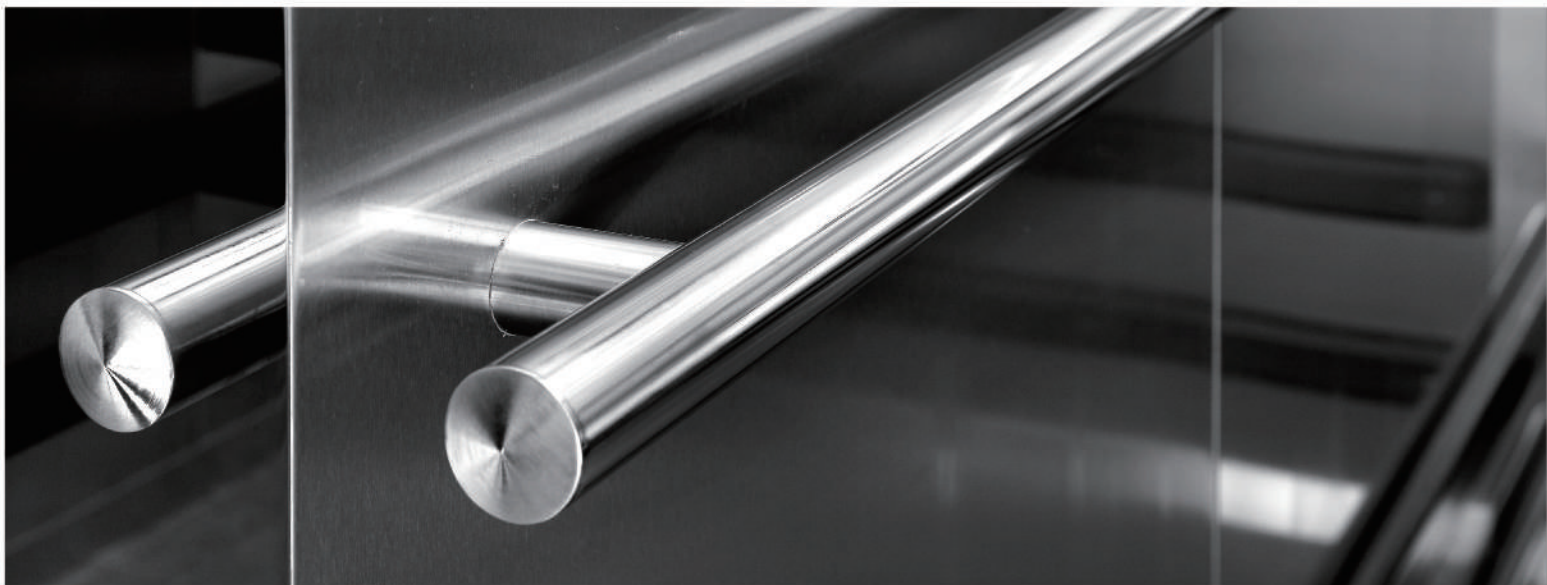

## 扶手(可选) Handrail(optional)



KL-FS 001

发纹不锈钢单管  
Stainless steel hairline mono-tube

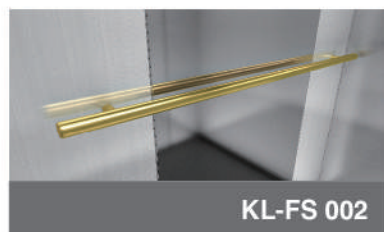

KL-FS 002

镜面钛金不锈钢单管  
Titanium gold mirror stainless steel mono-tube



KL-FS 003

发纹不锈钢双管  
Stainless steel hairline double-tube

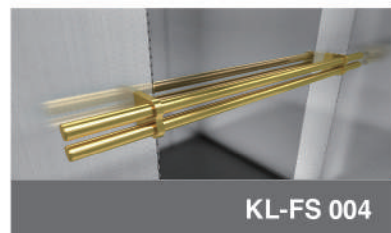

KL-FS 004

镜面钛金不锈钢双管  
Titanium gold mirror stainless steel double-tube



KL-FS 005

发纹不锈钢三联管  
Stainless steel hairline tri-tube

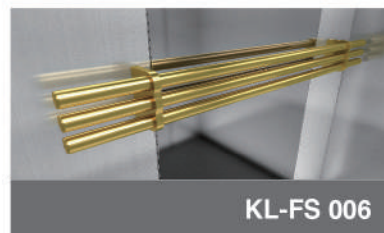

KL-FS 006

镜面钛金不锈钢三联管  
Titanium gold mirror stainless steel tri-tube

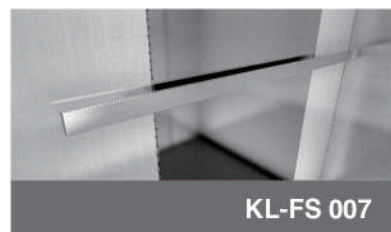

KL-FS 007

发纹板方扶手  
Hairline plate, square handrail

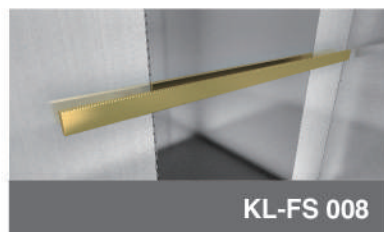

KL-FS 008

钛金板方扶手  
Titanium gold plate, square handrail



KL-FS 009

不锈钢短纹, 圆弧头  
Short grain stainless steel, arc head

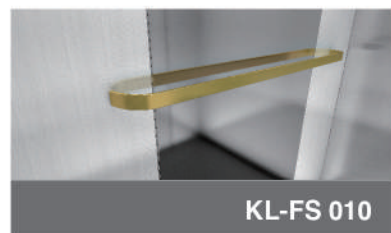

KL-FS 010

不锈钢钛金短纹, 圆弧头  
Short grain titanium gold stainless steel, arc head

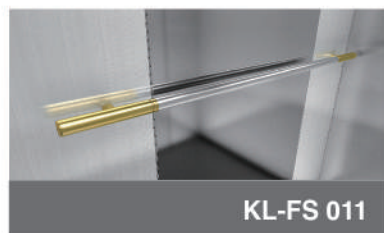

KL-FS 011

不锈钢, 钛金组合  
Combination of stainless steel and titanium gold

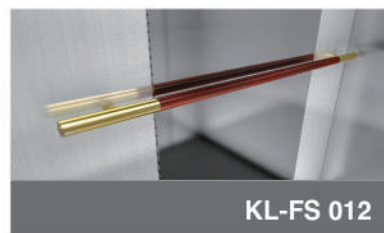

KL-FS 012

圆木和钛金组合  
Combination of round wood and titanium gold

## 厅门 Landing door



KL-TM 001  
标配 Standard

厅门: 发纹不锈钢  
Landing Door:  
Hairline stainless steel

门套: 发纹不锈钢  
Jamb: Hairline stainless steel



KL-TM 002  
标配 Standard

厅门: 喷粉钢板  
Landing Door:  
Dusting steel plate

门套: 喷粉钢板  
Jamb: Dusting steel plate



KL/M-4013  
可选 Optional

厅门: 镜面蚀刻不锈钢  
Landing Door:  
Stainless steel etched mirror

门套: 发纹不锈钢  
Jamb: Hairline stainless steel

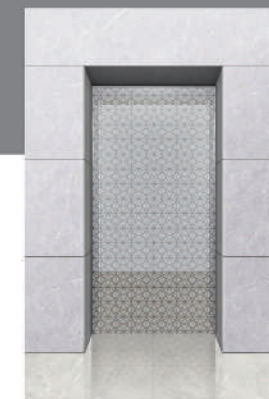

KL/M-4020  
可选 Optional

厅门: 镜面蚀刻不锈钢  
Landing Door:  
Stainless steel etched mirror

门套: 发纹不锈钢  
Jamb: Hairline stainless steel

## PVC地板 PVC floor



KL-JD 001

KL-JD 001 可选 Optional

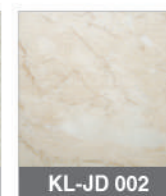

KL-JD 002

KL-JD 002 可选 Optional

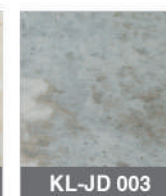

KL-JD 003

KL-JD 003 可选 Optional

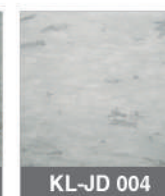

KL-JD 004

KL-JD 004 可选 Optional

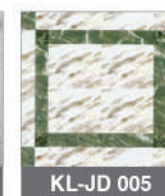

KL-JD 005

KL-JD 005 可选 Optional



KL-JD 006

KL-JD 006 可选 Optional



KL-JD 007

KL-JD 007 可选 Optional

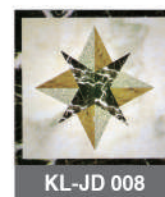

KL-JD 008

KL-JD 008 可选 Optional



KL-JD 009

KL-JD 009 可选 Optional

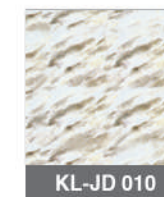

KL-JD 010

KL-JD 010 可选 Optional



KL / JD-4004

KL / JD-4004 可选 Optional

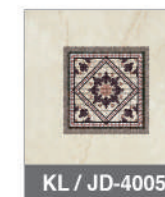

KL / JD-4005

KL / JD-4005 可选 Optional



KL / JD-4006

KL / JD-4006 可选 Optional

# 功能 Functions

● 标准功能；Standard    ● 无偿选配；Free optional    ● 有偿选配；Charged optional

## ● 抱闸力检测 Brake detection protection

主动定期测试抱闸力，通过提示故障及禁止电梯运行等方式，防止严重事故发生。

Actively and regularly test the brake force; prevent more serious accident by means of malfunction indication and running prohibition and so on.

## ● 曳引绳滑动检测 Traction Rope Slide Detection

实时监测滑动数据并且根据需要自动进入应急减速的安全运行模式。

It provides real-time monitoring of sliding data, and can automatically enter the safe operation mode for emergency according to requirements.

## ● 抱闸检测保护 Brake detection protection

通过抱闸臂检测开关对抱闸的打开与闭合实时监测。当抱闸未按要求打开时，系统将禁止电梯启动。

Brake arm detection switch executes real-time monitor to brake opening / closing. If the brake does not open by the requirements, the system will not start the elevator.

## ● 门区外不能开门的保护 Protection of none door opening outside door zone

在非门区状态，禁止自动开门。

Automatic door opening is forbidden under none door zone condition.

## ● 低速保护 Low-speed protection

为防止电梯在控制范围外低速运行导致安全问题而设置的保护。

It prevents elevator from low-speed running outside the control range causing any safety problem(s).

## ● 超载保护 Overload protection

在电梯关门运行前，当检测到超载信号时，电梯不能关门运行，并且关门按钮无效。超载消除后自动恢复正常。

Before the elevator shuts the door, if it detects overload signal, the elevator does not shut then, "door-shut button" becomes ineffective. After it removes overload problem, it re-starts automatically.

## ● 故障自动靠站 Automatic parking in trouble

正常运行中的电梯因故障在非平层区域内停止时，只要不是安全装置动作而引起，则电梯以低速向中间楼层方向进行自救运行，并在最近服务层停层开门，以防止困人事故的发生。

When the elevator stops in none leveling zone due to any trouble, if it is not caused by safety device action, it executes self-rescue running towards the middle floor direction at low speed. It parks and opens the door at the nearest service floor to prevent from any trapping accident.

## ● 电梯受阻保护 Protection of elevator blockage

系统发出启动命令，但在预定的时间内未能正常启动，或电梯在运行，但在预定的时间内未能到达一定的距离，电梯停止运行。

When the system runs start command, it does not start within preset time nor because it is during the elevator travelling, and it does not reach certain distance within preset time as well, the elevator stops accordingly.

## ● 司机运行 Attendant running

电梯工作在司机状态，系统按轿内指令信号运行。如有层站召唤信号，顺向层站召唤自动截车。平层停车后自动开门，但不自动关门，需由司机按动关门按钮。

When it is under the operator condition, the elevator system operates according to the car command signal. If landing call signal is available, it automatically cuts as per forward landing call. The door opens automatically after the leveling parking. But it does not shut automatically until the operator presses "door closing button".

## ● 消防返回 Fire-fighting return

消防开关闭合后系统进入消防返回状态：系统将消除所有层站召唤和轿内指令信号，自动返回消防基站，保持开门。如电梯正在反方向运行，则就近层停车不开门返回消防基站，保持开门。

When the fire-fighting switch closes, the system enters into fire-fighting running. The system will remove all the landing calls and car command signals, and it automatically returns to fire-fighting home landing, and the door keeps open. If the elevator is travelling in reverse direction, it parks at nearby floor, and returns to fire-fighting home landing with the door keeping closed, after that it keeps the door open.

## ● 消防运行 Fire-fighting running

消防开关闭合后系统进入消防运行：系统将消除所有层站召唤和轿内指令信号，自动返回消防基站，保持开门。如电梯正在反方向运行，则就近层停车不开门返回消防基站，保持开门并由消防员控制运行。

When the fire-fighting switch closes, the system enters into fire-fighting running. The system will remove all the landing calls and car command signals, and it automatically returns to fire-fighting home landing, and the door keeps open. If the elevator is travelling in reverse direction, it parks at nearby floor, and returns to fire-fighting home .

## ● 基站锁梯 Home landing elevator locking

电梯处于自动状态，关闭基站锁梯开关后，电梯将所登记的轿内指令服务完毕后自动返回基站，电梯进入驻停状态。一旦打开锁梯开关，电梯会立即退出驻停状态，投入正常运行。

When the elevator is under automatic condition, when it shuts home landing locking switch, the elevator will complete all the registered car command services, automatically return to home landing, it enters into parking condition. As soon as locking switch is on, it immediately returns from parking condition and goes into normal running.

## ● 误登记取消 Cancel the error-register

若乘客误按了某层轿内指令按钮并已登记（轿内指令灯亮），则在电梯未运行状态下，只需再按一次该层轿内指令按钮即将该登记取消（轿内指令灯灭）。

If the passenger presses the car command button at certain floor and has registered it by mistake, (by then the car indicating lamp is bright), if under the condition of none elevator running, you only press the car command button at the same floor to cancel the register. (By then the car indicating lamp dies out.)

## ● 轿厢到站钟 Car arrival gong

通过轿厢顶的钟声，提醒在轿厢内的乘客和等候在电梯候梯厅内的乘客该电梯即将到站。

Arrival gong on top of the car reminds the passengers in the car and those waiting in the hall that the elevator has arrived.

## ● 语音报站 Phonic station reporter

由语音报站装置通知乘客电梯运行相关信息：在电梯到站前播报将要到站的层楼，在关门运行前播报将要运行的方向等。

Phonic station reporter informs the passengers of the relevant elevator running information. It announces the arriving landing, the traveling direction etc. before door-close and running.

## ● 通电自动开门 Electrified automatic door-opening

每次电梯上电，如轿厢正在门区，电梯门将自动打开。

Every time when the elevator is electrified, if the car is in the door zone, the elevator door opens automatically.

## ● 自动返基站 Automatic return to home landing

无司机运行时，如果自动返基站功能设置有效，当无层站召唤信号时间到达预定的时间后，电梯自动返回基站。

In non-attendant running, if automatic return function to home landing is still effective, and no-landing call signal time fulfills preset time, the elevator returns to home landing automatically.

## ● 轿厢内照明及风扇自动停止 Automatic stop of the car illumination and fan

如一定时间电梯无人使用，轿厢内照明和风扇将自动关闭。接到任何层站召唤命令后自动打开。

If nobody uses the elevator within certain period of time, the car illumination and fan shut off automatically and re-opens on receiving any landing call command(s).

## ● 楼层信号自动校正 Automatic correction of floor signal

如果楼层显示位置有误差，系统在运行中检测到端站开关后，将自动校正楼层显示。

If the floor display position has error, after the system detects terminal switch in the travel, it will automatically correct the floor display.

## ● 轿内反向指令消除 Cancellation of the reverse command(s) in the car

当电梯运行至最远端楼层换速时，清除所有的轿内指令登记。

When the elevator travels to the farthest floor and changes the speed, it removes all the car command register.

## ● 呼梯按钮嵌入自诊断 Self-diagnostic embedded call button

若某一层站召唤按钮按下时间超过20秒而未断开，则系统认为该按钮嵌入。以后对该层层站召唤不予登记，且该按钮对应的应答灯不断闪烁报警。当该按钮断开时，退出上述状态。

If you press call button at certain landing for over 20 second, and it still does not disconnect, the system assumes that it is embedded button. It does not register the landing call of the same floor afterwards. Responsive lamp which corresponds to the button keeps flickering and alarming. When the button disconnects, it exits from above condition.

## ● 再平层功能 Re-leveling function

电梯停在当前层，当过多乘客进入电梯或离开电梯时，由于钢丝绳的伸长或缩短，轿厢脱离平层区域，电梯将在开门的情况下以低速运行至平层位置。

If the elevator parks on the current floor, when too many passengers enter into / leave the elevator, the car is separated from the leveling zone because of wire rope extension or shortening. The elevator will then travel to the leveling position at low speed under the condition of door-opening.

## ● 信号接口装置 Signal interface position

通过信号接口装置输出电梯的基本运行状态信号。

It outputs basic running condition signal through the signal interface device.

## ● 自动应急平层运行 Automatic emergency leveling travel

如果自动应急平层功能设置有效，并配置了“自动应急平层装置”，满足自动应急平层条件，电网停电后由电梯自动应急平层装置供电运行到达最近层站的平层位置，开门，让乘客安全撤离轿厢。

If automatic emergency leveling function setting is effective, it is equipped with "automatic emergency leveling device" to satisfy automatic emergency leveling conditions. After power grid fails, automatic emergency leveling device supplies electricity and the elevator travels to the leveling position of the nearest landing. It opens the door, for safe evacuation of the passengers from the car.

## ● 远程监控 Long-distance monitor

通过信号接口装置、及无线网络技术，用户只需登入相应服务器即可查看信息，对电梯故障率、故障时间等进行统计分析也可实现故障短信报警。

Through signal interface device and wireless network technology, user can log in the corresponding server to check information, make statistical analysis of elevator failure rate and failure time, and achieve fault message alarm.

## ● 能量回馈 Energy feedback

当配置了能量回馈装置时，将电梯轻载上行和重载下行时产生的能量回馈电网或供周边设备使用，以达到节能目的。

When energy feedback device is installed, the energy produced during the elevator light-load up-motion and heavy-load down-motion will be used by power grid and the surrounding equipments. It fulfills the energy-saving purposes.

## ● 电动松闸开关 Electric brake release switch

康力无机房电梯特别配置了电动松闸开关，使紧急救援时更加及时便捷。

CANNY machine roomless elevator is specially equipped with the electric brake release switch so that the emergency relief can be more timely and conveniently.

# 土建参数 Construction parameters

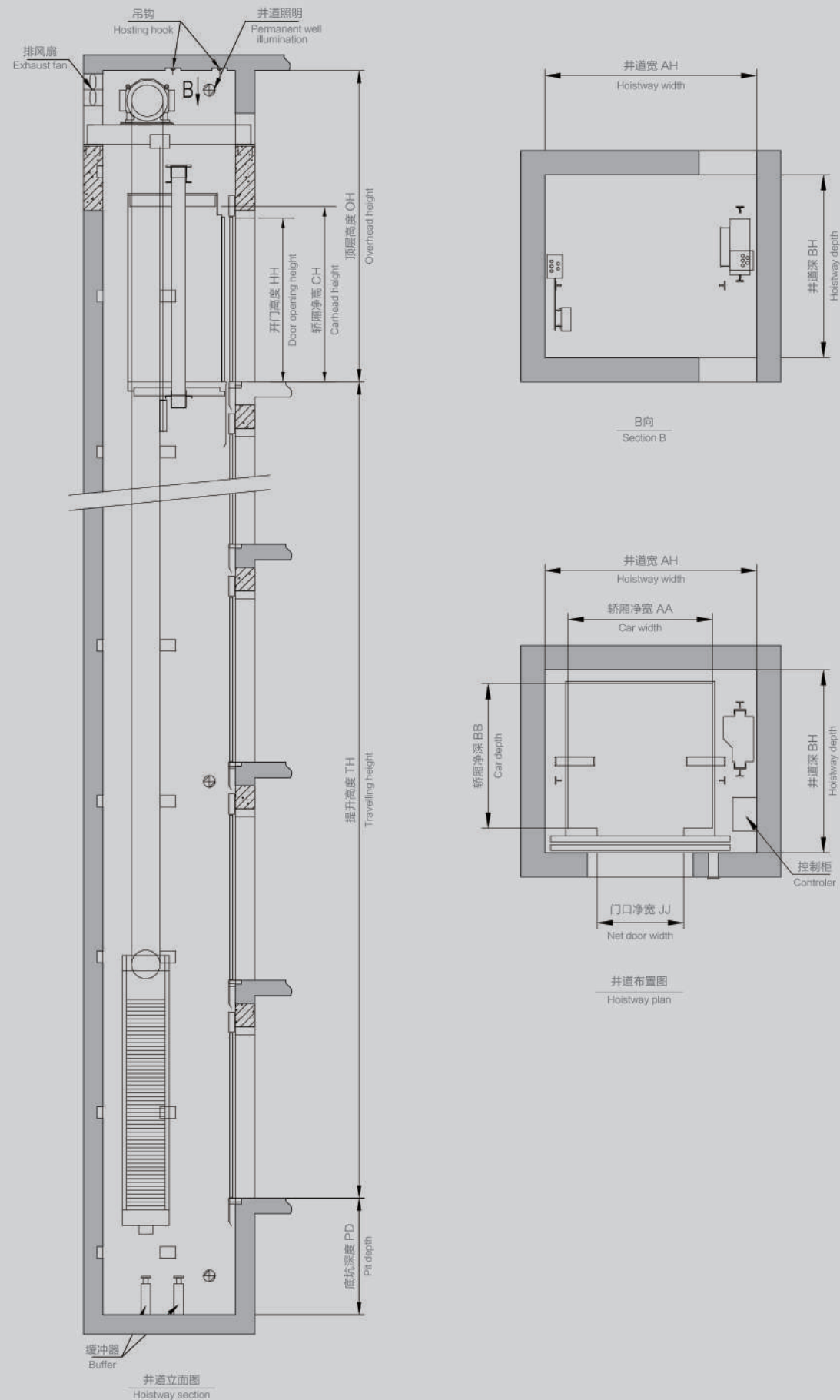

## KLW 无机房电梯参数表 KLW Machine Roomless Elevator Parameter Table

载重量 (Kg) Loading capacity	额定速度 (m/s) Rated speed	开门宽度 (mm) Door opening width	开门高度 (mm) Door opening height	轿厢尺寸 (mm) Car size			井道尺寸 (mm) Hoistway size		顶层高度 (mm) Top floor height	底坑深度 (mm) Pit depth	最大提升高度 (m) Max. travelling height
				宽 Width	深 Depth	高 Height	宽 Width	深 Depth			
450	1.0	800	2100	1100	1100	2250	1800	1700	3800 (3900) / 3850 (3950)	1450	30 / 50
	1.6	800	2100	1100	1100	2250	1800	1700	3950 (4050) / 4000 (4100)	1550	30 / 60
630	1.0	800	2100	1100	1400	2250	1800	1800	3800 (3900) / 3850 (3950)	1450	30 / 50
	1.6	800	2100	1100	1400	2250	1800	1800	3950 (4050) / 4000 (4100)	1550	30 / 60
800	1.0	800	2100	1300	1400	2250	2000	1800	3800 (3900) / 4100	1450	30 / 50
	1.6	800	2100	1300	1400	2250	2000	1800	4050 / 4200	1550	30 / 60
1000	1.75	800	2100	1300	1400	2250	2000	1800	4050 (4100) / 4200	1600	30 / 80
	1.0	900	2100	1500	1500	2250	2200	1900	3800 (3900) / 4100	1450	30 / 50
1150	1.6	900	2100	1500	1500	2250	2200	1900	4050 / 4200	1550	30 / 60
	1.75	900	2100	1500	1500	2250	2200	1900	4050 (4100) / 4200	1600	30 / 80
1250	2.0	900	2100	1500	1500	2250	2200	1900	4700	1650	95
	1.0	1000	2100	1700	1500	2250	2550	1950	3900 (4000) / 4200 (4300)	1500	30 / 50
1350	1.6	1000	2100	1700	1500	2250	2550	1950	4150 (4250) / 4300 (4400)	1600	30 / 60
	1.75	1000	2100	1700	1500	2250	2550	1950	4150 (4250) / 4300 (4400)	1650	30 / 80
1600	2.0	1000	2100	1700	1500	2250	2550	1950	4700	1700	95
	1.0	1100	2100	1950	1500	2250	2800	1950	3900 (4000) / 4200 (4300)	1500	30 / 50
2000	1.6	1100	2100	1950	1500	2250	2800	1950	4150 (4250) / 4300 (4400)	1600	30 / 60
	1.75	1100	2100	1950	1500	2250	2800	1950	4150 (4250) / 4300 (4400)	1650	30 / 80
2000	2.0	1100	2100	1950	1500	2250	2800	1950	4700	1700	95
	1.0	1100	2100	2000	2000	2250	2900	2400	3900 (4000) / 4200 (4300)	1500	30 / 50
2000	1.6	1100	2100	2000	2000	2250	2900	2400	4150 (4250) / 4300 (4400)	1600	30 / 60
	1.75	1100	2100	2000	2000	2250	2900	2400	4150 (4250) / 4300 (4400)	1650	30 / 80
2000	2.0	1100	2100	2000	2000	2250	2900	2400	4700	1700	95

备注: 轿厢净高 (不含吊顶) 括号内为梁式结构 永磁门机 2.0m/s为梁式结构 30m以下无补偿链配置 2.0m/s全部补偿链配置



## 全国分公司服务网络 National branch service network

### 辽宁分公司

销售热线: 024-31981333 传真: 024-31981222  
地址: 沈阳市大东区滂江街26-1国际公寓2916

### 大连分公司

销售热线: 0411-86552277 传真: 0411-86552299  
地址: 大连市中山区民康街15号报业大厦16层E

### 盘锦分公司

销售热线: 0427-2828611 传真: 0427-2829611  
地址: 辽宁省盘锦市兴隆台区大商新玛特C座2102室

### 黑龙江分公司

销售热线: 0451-82346098 传真: 0451-82318292  
地址: 黑龙江省哈尔滨市道里区群力第四大道399号汇智广场西楼1004室

### 吉林分公司

销售热线: 0431-86770000 传真: 0431-81030300  
地址: 长春市经济技术开发区临河街5445号圣豪汇商705室

### 北京分公司

销售热线: 010-65505559 传真: 010-65505562  
地址: 北京市朝阳区八里庄西里97号住邦2000商务中心4号楼10层

### 内蒙古分公司

销售热线: 0471-6289116 传真: 0471-6922767  
地址: 呼和浩特市回民区新华西街明泽广场A座21层2110室

### 河北分公司

销售热线: 0311-66792031 转 8002 传真: 0311-87893130  
地址: 石家庄市建设南大街29号众鑫大厦818-820室

### 天津分公司

销售热线: 022-58306090 传真: 022-58306091  
地址: 天津市红桥区光荣道与保康路交口宝能创业中心B座24层2412室

### 山西分公司

销售热线: 0351-8371869 传真: 0351-8371859  
地址: 太原市小店区平阳路1号金茂国际数码中心A座16层F室

### 陕西分公司

销售热线: 029-88332244 传真: 029-88332244-831  
地址: 西安市莲湖区唐延路北段22号金辉国际广场11层

### 甘肃分公司

销售热线: 0931-8811752 传真: 0931-8432645  
地址: 甘肃省兰州市城关区澳兰名门B2座708室

### 新疆分公司

销售热线: 0991-4815313 传真: 0991-4815795-815  
地址: 新疆乌鲁木齐沙依巴克区友好北路793号高地中心1105室

### 河南分公司

销售热线: 0371-60189221  
地址: 郑州市郑东新区康平路永平路郑东商业中心写字楼一号楼17楼1707

### 山东分公司

销售热线: 0531-55693961 传真: 0531-55693965  
地址: 济南市市中区经四路13号万达广场C座办公楼2606室

### 青岛分公司

销售热线: 0532-68890088 传真: 0532-89092106  
地址: 青岛市市北区山东路177号鲁邦广场B座1106-1107

### 烟台分公司

销售热线: 0535-6887005 传真: 0535-6887005  
地址: 山东省烟台市莱山区银海路566号南山世纪华府13-2-2802

### 南京分公司

销售热线: 025-58812988 传真: 025-84519155-81  
地址: 南京市洪武路359号福鑫大厦西2602室

### 苏州分公司

销售热线: 0512-65166725 传真: 0512-65166721  
地址: 苏州工业园区苏虹中路225号星虹国际1幢2113室

### 无锡分公司

销售热线: 0510-85861251 传真: 0510-85861252  
地址: 无锡市滨湖区梁青路58号华邨国际大厦A座1501室

### 徐州分公司

销售热线: 0516-83919000 传真: 0516-83919005  
地址: 徐州市庆丰路绿地城市广场瀛海写字楼A座706室

### 上海分公司

销售热线: 021-62828058/62827558 传真: 021-62828360  
地址: 上海市延安西路1221号2203室

### 浙江分公司

销售热线: 0571-89971040 传真: 0571-86590365  
地址: 杭州市新塘路19号采荷嘉业5幢1204室

### 安徽分公司

销售热线: 0551-62671797 传真: 0551-62313639  
地址: 安徽省合肥市蜀山区望江西路69号西湖国际广场A座603室

### 芜湖分公司

销售热线: 0553-3856158  
地址: 芜湖市镜湖区长江中路66号 徽商财富广场北楼1802室

### 江西分公司

销售热线: 0791-88223016 传真: 0791-88399056  
地址: 南昌市高新开发区紫阳大道绿地新都会紫峰(幢)大厦写字楼34层3402室

### 湖北分公司

销售热线: 027-82660063 传真: 027-85770699  
地址: 武汉市江汉区淮海路中段泛海国际SOHO城2605-2606室

### 襄阳分公司

销售热线: 0710-3287220 传真: 0710-3287220  
地址: 襄阳市高新区长虹北路万达广场1栋二单元1902室

### 湖南分公司

销售热线: 0731-85787755 传真: 0731-85787722  
地址: 长沙市岳麓区岳麓大道57号奥克斯广场B座1127-1129

### 重庆分公司

销售热线: 023-67877015 传真: 023-67877025  
地址: 重庆市渝中区大坪正街160号万科锦程1栋26-6

### 四川分公司

销售热线: 028-61320037 传真: 028-87321179  
地址: 四川省成都市高新区新世纪环球中心西区8-1-1707

### 云南分公司

销售热线: 0871-68355199 传真: 0871-68355299  
地址: 云南省昆明市五华区人民中路36号如意大厦11A室

### 贵州分公司

销售热线: 0851-86515286 传真: 0851-86515286转81  
地址: 贵阳市观山湖区金阳南路6号世纪城购物中心D栋写字楼23层5号

### 广西分公司

销售热线: 0771-5517626 传真: 0771-5505713  
地址: 南宁市民族大道92-1号新城国际1401号

### 广东分公司

销售热线: 020-38021060 传真: 020-38021410  
地址: 广州市天河区天河路625号天娱广场东塔1007-1008室

### 深圳分公司

销售热线: 0755-83865618 传真: 0755-83865618  
地址: 深圳市福田区益田路3008号皇都广场A座1906室

### 珠海分公司

销售热线: 0756-2260550 传真: 0756-2260695  
地址: 珠海市香洲区银桦路102号6栋优特科技大厦909室

### 福建分公司

销售热线: 0591-88596982 传真: 0591-88594630  
地址: 福州市五一中路88号平安大厦21G

## 用户应完成的工作 The user's tasks

- 本图按有关电梯技术标准要求绘制，需复核后作为电梯安装依据。
- 曳引机承重梁如需埋入墙内，则支承长度应超过墙中心20mm，且不应小于75mm。
- 安装完成后，地面装饰应与厅门地坎上表面有一高度适当的台阶，以防止水或其它杂物进入井道。
- 安装时浇灌的物体应能满足相关图示要求。
- 缓冲器底座制作时应在安装人员的指导下施工。

- It makes the drawing according to the relevant lift technical standard, It needs to be checked and confirmed by the user before it becomes the lift installation proof.
- It shall be embedded in the wall for the machine supporting beam of the traction machine, Then the supporting length shall be 20mm more than the wall center, It shall not be less than 75mm.
- After the installation completion, the ground decoration shall have a proper height step in the sill surface to prevent water or other impurity from entering into the well.
- The casting object in the installation shall satisfy the relevant drawing requirements.
- The buffer base shall be made under the directions of the installers.