



扫描二维码
关注康力电梯门户网站
Scan the QR code and pay attention to
CANNY ELEVATOR Portal Website.



扫描二维码
关注康力电梯微信公众号
Scan the QR code and pay attention to
CANNY ELEVATOR WeChat Public Number

KONL® 康力电梯
CANNY ELEVATOR

KRF/KLRP

自动人行道

MOVING WALK



康力电梯股份有限公司 CANNY ELEVATOR CO.,LTD.

◎地址：江苏省滨湖高新技术产业开发区康力大道888号
◎电话：0512-63290000
◎传真：0512-63293938
◎网址：www.canny-elevator.com
◎电子信箱：(国内) marketing@canny-elevator.com
(国外) export-canny@163.com
export@canny-elevator.com
◎400客户服务热线：400-188-2367
◎邮编：215213

◎Add: No.888, Kangli Road, FOHO New & Hi-Tech Industrial
Development Zone, Jiangsu Province, China.
◎Tel: +86-512-63290000 63297851
◎Fax: +86-512-63299709
◎URL: www.canny-elevator.com
◎E-mail: export-canny@163.com
export@canny-elevator.com
◎P.C: 215213

本书为一般信息类出版物，我们保留随时更改产品设计和说明的权利，所有图片和颜色可能与实物有所不同，请以实物为准。
康力电梯股份有限公司 © 版权所有 2016-V1.0版

自动人行道

Moving
Walk

大音希声 大象无形

Great Sound is Hard to Hear,
Great Form Has No Shape



机场



火车站



百货商场

大宽度、大流量

康力自动人行道不断引进和开发先进技术，
完美打造大宽度大流量自动人行道，
适用于大型机场、火车站、百货商场等场所，引领建筑新空间。

Large Width, High Flow

CANNY constantly introduces and develops advanced technologies,
creates perfect large-width high-volume moving walks,
which are suitable for large airports, train stations, shopping malls and
other places, and builds new space.





超强输送，领衔空间

- ◆大高度高强度扶手护栏，裙板的防护高度达1000mm，增加了安全性能。
- ◆踏板宽度最大可达到1.4米，实现了超大流量的乘客和货物输送。
- ◆先进的微机板控制系统，容量大，反应速度快，稳定性能高，功能更齐全。（选配）

1000mm

防护高度

1.4m

踏板宽度

先进

微机板（选配）

Super Transportation, Leading Space

- ◆ Tall handrail and guardrail with high strength, skirt panel with a height of 1000mm, increase safety performance.
- ◆ The maximum pedal width can reach 1.4 m, fully meet the requirement of large flow of passengers and cargo transportation.
- ◆ Advanced microcomputer board control system has high capacity, fast response, high stability, and complete functions. (Optional)

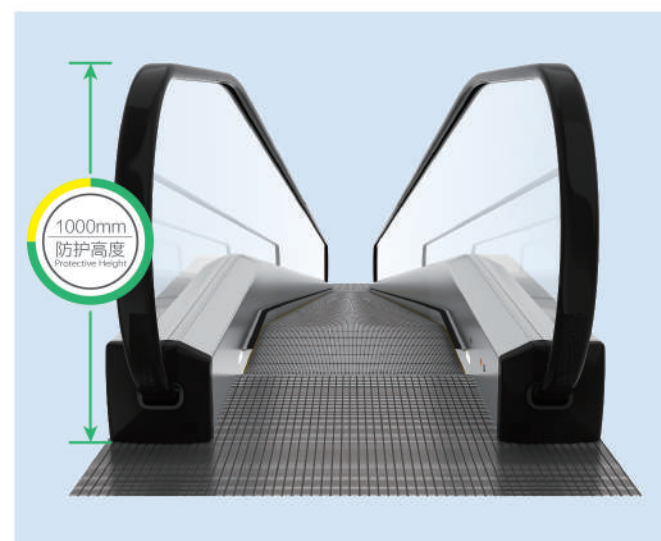

扶手护栏
Handrail Balustrade

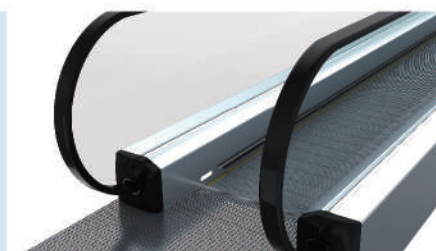

踏板 Pallet

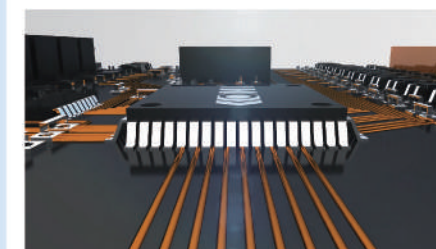

微机板（选配）
Microcomputer Board (Optional)



精湛技艺，至极方休

- ◆ 桁架采用机器人焊接技术，大大提升制造工艺、具有品质精益求精、坚固耐用、美观大方等优点。
- ◆ 超静音主机有效预防振动，踏板具有特殊静音减震设计，涨紧架装置更有效防止噪音。
- ◆ PLC控制自动加油润滑系统，在运行过程中给传动链理想的自动润滑，延长传动机构的使用寿命。



机器人焊接技术
Robot Welding Technology

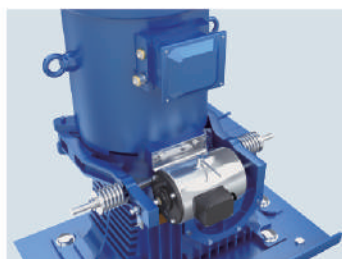

超静音主机
Ultra-quiet Main Engine

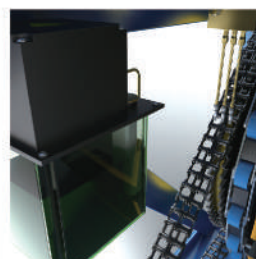

PLC控制自动加油
PCL Automatic Lubrication

Superb Artistry, Exquisite Elevator

- ◆ Truss adopts robot welding technology, which greatly enhances the manufacturing process and makes it more sturdy, wearable and beautiful.
- ◆ The ultra-quiet main engine can effectively prevent vibration, pedal adopts special mute damping design, tensioning frame device can effectively prevent noise.
- ◆ PLC automatic lubrication system provides ideal lubrication for gearing chain during operation, extending the service life of transmission device.

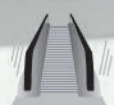

防止振动



防止噪音



扶手导轨滚动群轮组
Handrail Guide Rail Chain Roller Group

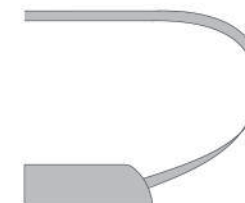

传统自动人行道
Traditional Moving Walk

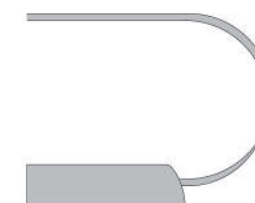

康力自动人行道
CANNY Moving Walk

大圆弧半径回转扶手导轨

匹配使用滚动群轮组，有效减少摩擦，延长扶手带的使用寿命。

Large Radius Rotary Handrail Guide Rail

It is matched with rolling wheel group, effectively reducing friction and prolonging the service life of handrail belt.



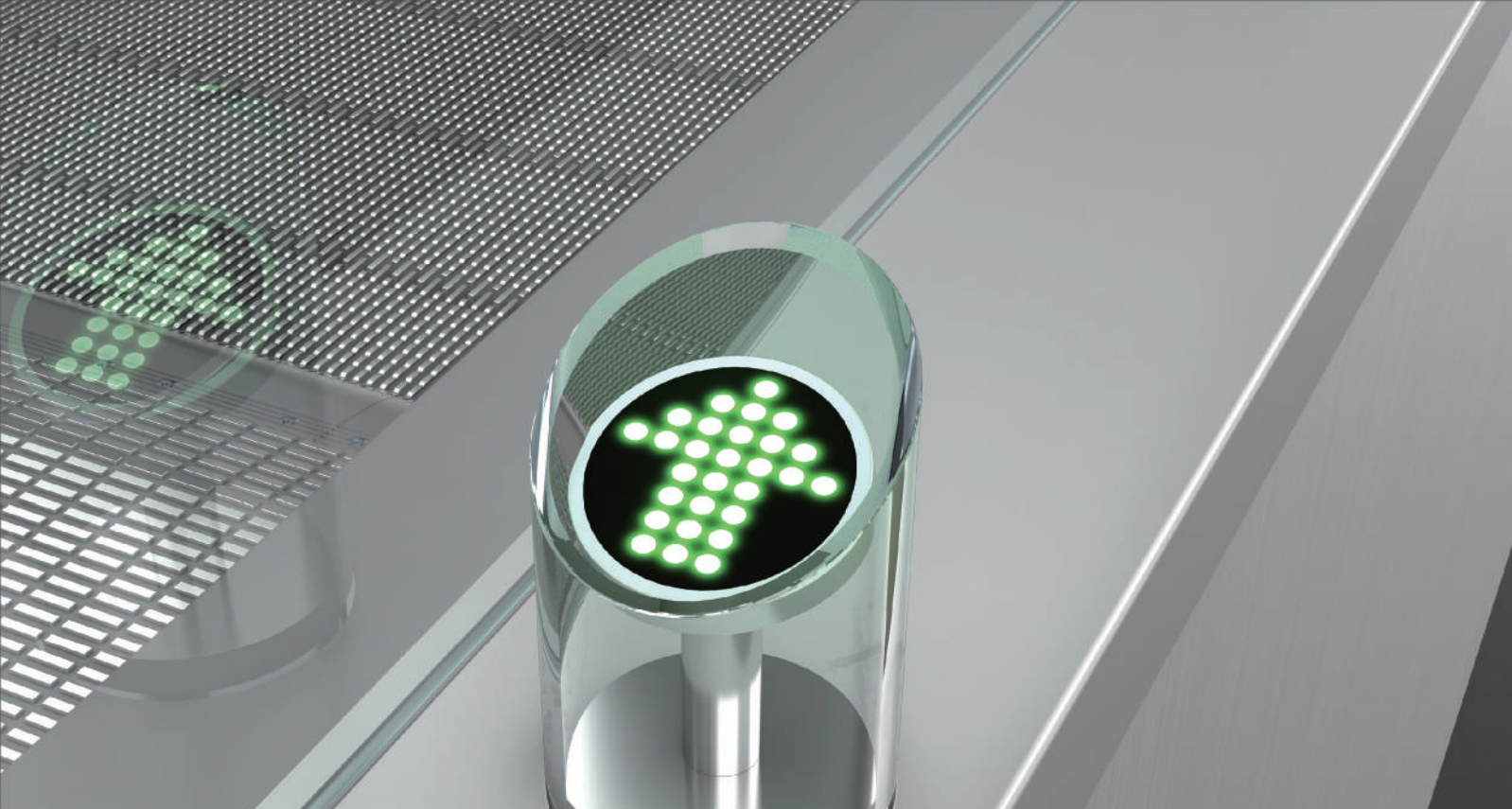

新型梳齿安全装置

当异物带入运动踏板和静止梳齿板之间，
触发监控梳齿板两侧的安全开关，自动人行道就会自动停止。

New Comb Safety Device

If any foreign object is stuck between the moving pedal and stationary comb plate, the safety switches that is put on both sides of comb plate can be triggered, thus the moving walk will be automatically stopped.

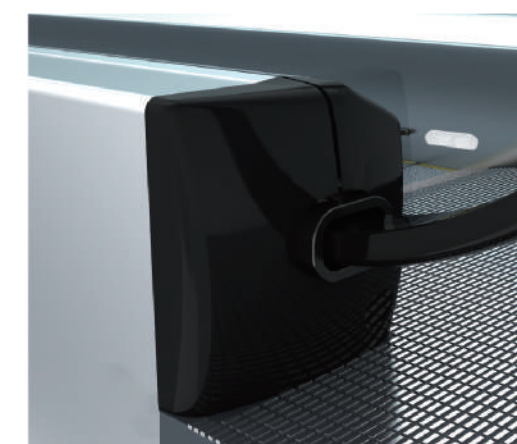
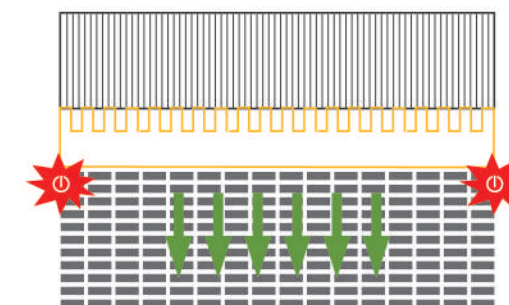

扶手入口安全装置

如果有异物卡在橡胶头和扶手带之间，
其橡胶入口后面的安全开关就会启动，使自动人行道制停。

Handrail Entry Safety Device

If any foreign object is stuck between the rubber head and handrail, the safety switch behind the rubber entrance will start automatically to stop the moving walk from moving.

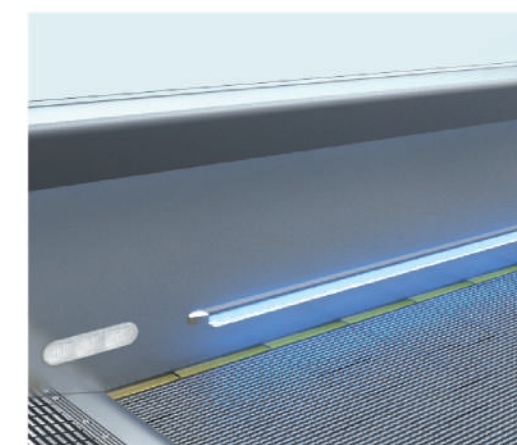

围裙照明（选配）

不仅展现了光束的美观大方，
同时又强调了自动人行道在整栋大楼中的可见度，
使乘坐更加舒心和安全。

Skirting Panel Lighting (Optional)

It not only demonstrates the beautiful light beam, but also emphasizes the visibility of moving walk in the entire building, making carriage more comfortable and safer.



安全定位，自由先行

再先进的技术功能，再美观的外在表现，都是为了您的安全出行所服务，在您看不见的地方，我们细心呵护，我们要做的就是您想要的。

Safety Positioning, Free Operation

All advanced technologies and beautiful appearances are designed to provide services for your safe travel, we will make you carefully protected from details, and provide you with what you want.



急停按钮
Emergency Stop Button

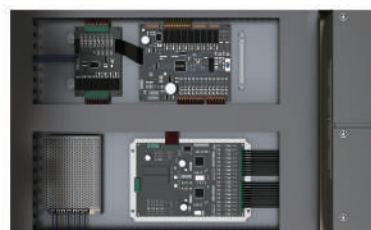

安全电路板
Safety Circuit Board

- ◆ 当自动人行道发生紧急故障时，可按下急停按钮，立刻停止自动人行道运行，防止更大的事故发生。
- ◆ 采用先进的安全电路板对自动人行道安全保护装置进行实时监控，及时消除运行隐患，减少维护时间，从而确保乘客安全。
- ◆ 运行方向指示灯位于扶手带入口处，以显示运行或禁行指示，确保乘客安全自如地乘坐。（选配）
- ◆ When an emergency occurs to the moving walk, pressing the emergency stop button can immediately stop the moving walk from running and avoid more accidents.
- ◆ Advanced safety circuit board is adopted to provide real-time monitoring of the safety protection devices of moving walk, timely eliminate operational risks and reduce maintenance time, thus ensuring the safety of passengers.
- ◆ Running direction indicator are placed at the handrail belt entrance to indicate the operation or stop of moving walk, so as to enable passengers to have safe and free user experience. (Optional)

安全装置

Safety Device

标准安全装置	Standard Safety Device
1 缺相、错相保护	Lack of Phase, Error Phase Protection
2 马达超载保护	Motor Over-load Protection
3 电器回路保护	Electrical Appliance Loop Protection
4 扶手带入口保护	Handrail Belt Protection
5 梳齿板安全保护装置	Comb Plate Safety Device
6 梯级塌陷保护装置	Step Sagging Protection Device
7 驱动链断裂保护	Broken Drive-chain Safety Device
8 梯级链断裂保护	Broken Step Chain Protection
9 超速保护	Over-speed Protection
10 非操作逆转保护	Direction Reversal Protection
11 警戒线	Security Line
12 紧急停止按钮	Emergency Stop Button
13 围裙板保护	Skirt Panel Protection
14 制动器保护	Brake Protection

标准安全装置	Standard Safety Device
15 检修安全开关	Safety Inspection Switch
16 梯级照明	Step Illumination
17 启动警铃装置	Alarm Bell Starting Device
18 前沿板打开保护装置	Landing Plate Contact
19 扶手带速度监控	Handrail Belt Speed Monitor
20 围裙板刷	Skirt Panel Brush
21 制动距离检测	Braking Distance Inspection
22 踏板缺失监测装置	Pallet Missing Detection

可选用的安全装置	Optional Safety Device
23 防火卷帘门联动装置	Fire Shutter Door Interlocks
24 附加制动器	Auxiliary Brake

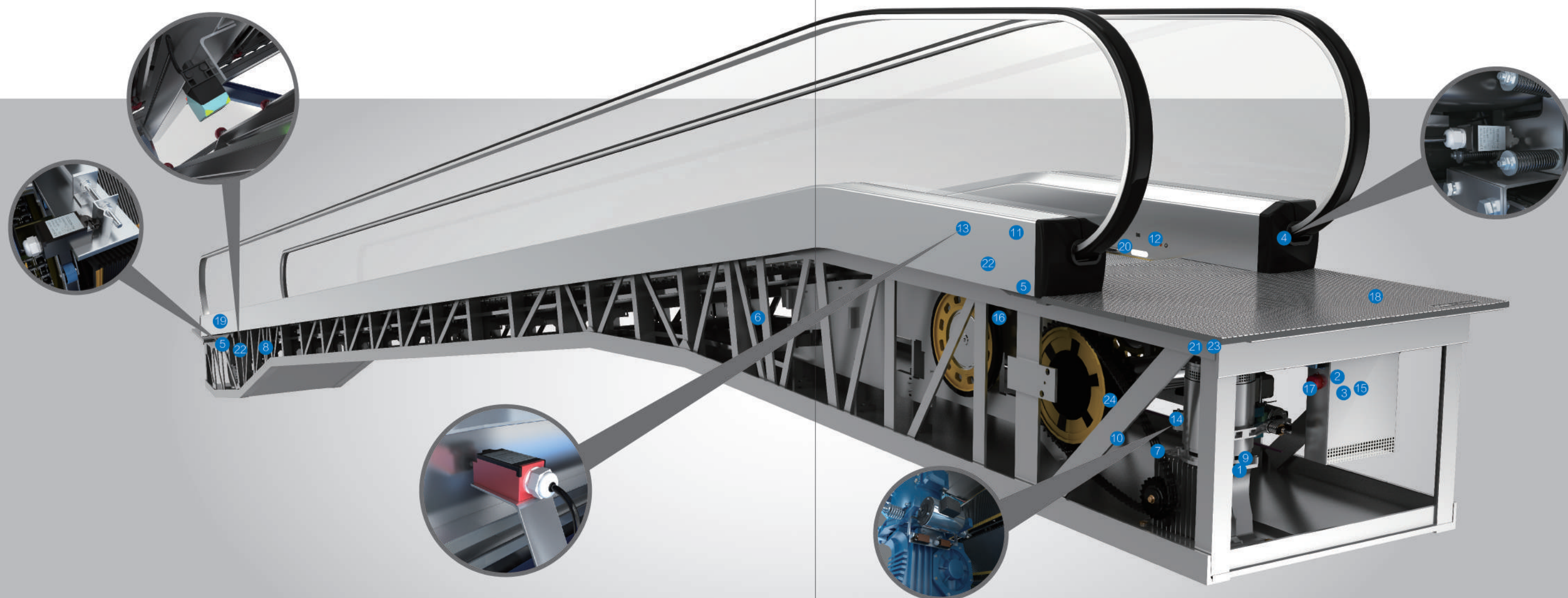

独特设计, 品鉴美感

Unique Design, Taste of Beauty

踏板 Pallet

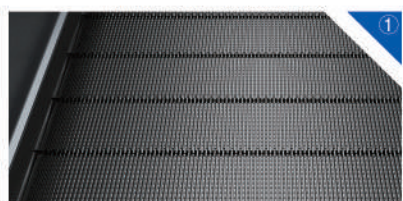

黑色不锈钢 (KLRP, KRF-RS标配)
Black Stainless Steel (KLRP, KRF-RS Standard)

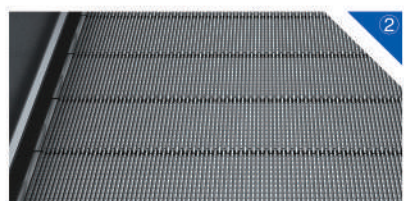

银灰色铝合金 (KRF, KRF-B标配)
Silver Grey Aluminum Alloy (KRF, KRF-B Standard)

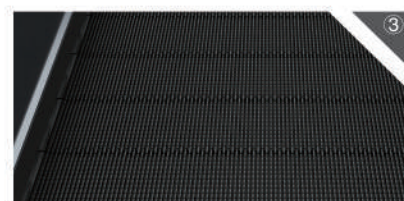

黑色铝合金 (KRF, KRF-B选配)
Black Aluminum Alloy (KRF, KRF-B Optional)

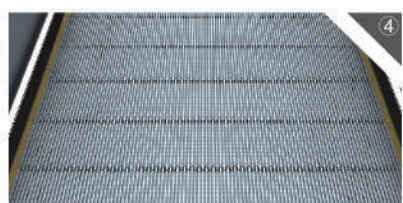

边框黄色塑料 (选配)
Frame Yellow Plastic (Optional)

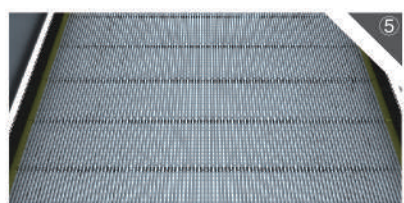

边框黄色喷涂 (选配)
Frame Yellow Spraying (Optional)

护壁板颜色 Balustrade Color



无色透明 (标配)
Colorless and Transparent (Standard)

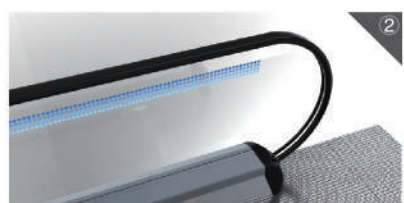

透明带丝印 (选配)
Transparent Silk Screen (Optional)



古铜色 (选配)
Bronze (Optional)

梳齿 Comb Teeth

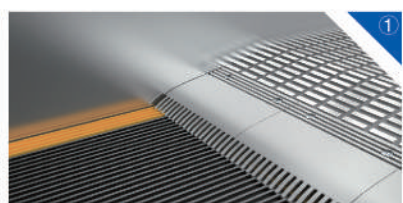

铝 (标配)
Aluminum (Standard)

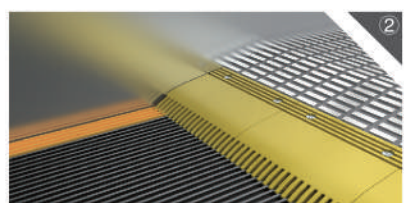

铝表面黄色喷漆 (选配)
Aluminum Surface Yellow Paint (Optional)

扶手带颜色 Handrail Color



黑色 (标配)
Black (Standard)



灰色 (选配)
Gray (Optional)



红色 (选配)
Red (Optional)



橙色 (选配)
Orange (Optional)



蓝色 (选配)
Blue (Optional)

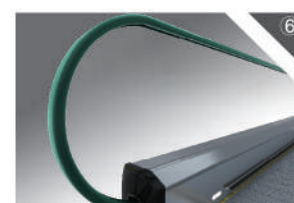

浅绿蓝 (选配)
Greenish Blue (Optional)

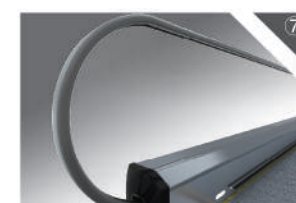

浅褐色 (选配)
Light Brown (Optional)

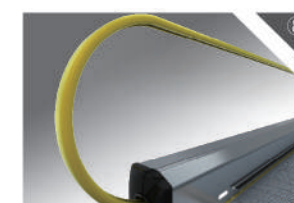

黄色 (选配)
Yellow (Optional)

围裙照明 Skirting Panel Lighting

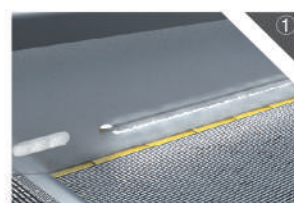

白色 (选配)
White (Optional)

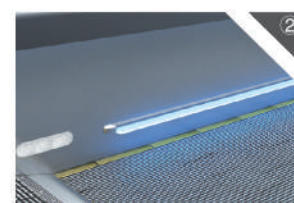

蓝色 (选配)
Blue (Optional)

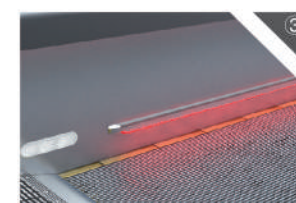

红色 (选配)
Red (Optional)

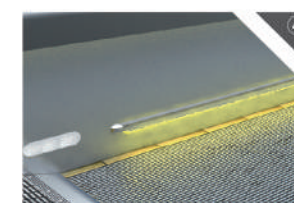

黄色 (选配)
Yellow (Optional)

梳齿照明 Comb Teeth Lighting

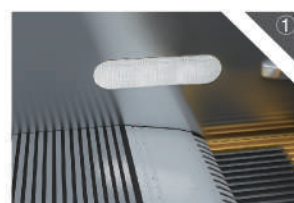

白色LED (选配)
White LED (Optional)

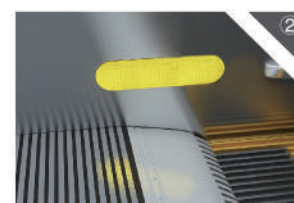

黄色LED (选配)
Yellow LED (Optional)

运行方向指示灯 Running Direction Indicator



透明塑料LED显示 (选配)
Transparent Plastic LED Display (Optional)



黑色塑料点阵显示 (选配)
Black Plastic Matrix Display (Optional)

注: 图片系电脑绘制, 可能与实际略有不同, 以实物为准。
Note: Pictures have been drawn by computer. It might be slightly different from actual colors. Please take real product as criterion.

KRF单圆弧F型自动人行道
KRF Inclined Moving Walk

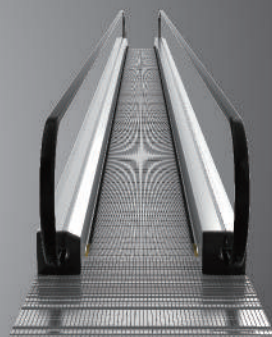

KRF-B单圆弧B型自动人行道
KRF-B Inclined Moving Walk

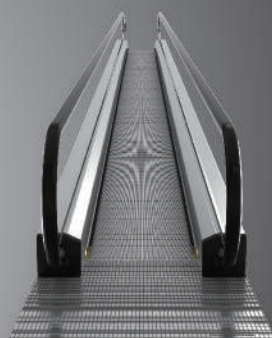

KRF-RS双圆弧F型自动人行道
KRF-RS Inclined Double-arc Moving Walk



KLRP水平型自动人行道
KLRP Horizontal Moving Walk

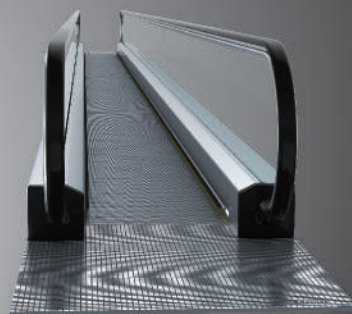

自动人行道规格表 Moving Walk Specification Table

型号 Model	KRF	KRF-B	KRF-RS	KLRP
主辅滚轮直径mm Main and Auxiliary Wheel Diameter (mm)	Φ70	Φ70	Φ70	Φ75
倾斜角度 Angle of Inclination	12° /11° /10°	12° /11° /10°	12° /11° /10°	0°
踏板长度 (mm) Pallet Length (mm)	1000/800	1000/800	1000/800	1400/1200/1000
踏板宽度 (mm) Pallet Width (mm)	133.33	133.33	266.66	400/266.66
额定速度 (m/s) Rated Speed (m/s)	0.5/0.65	0.5/0.65	0.5/0.65	0.5/0.65
最大提升高度 (m) Max. Rise H (m)	8	8	6	—
水平长度 (m) Horizontal Length (m)	—	—	—	12≤L≤100

自动人行道配置表 Moving Walk Configuration Table

型号 Model	KRF	KRF-B
踏板、梳齿板类型(标配) Types of Pedals and Comb Plate (Standard)	SUS430不锈钢贴片楼层盖板 SUS430 Stainless Steel Patch Floor Cover Plate Decking	SUS430不锈钢贴片楼层盖板 SUS430 Stainless Steel Patch Floor Cover Plate Decking
踏板、梳齿板类型(选配) Types of Pedals and Comb Plate (Optional)	铝合金贴片楼层盖板/SUS304不锈钢贴片楼层盖板 Aluminum Alloy Floor Cover Plate Decking / SUS304 Stainless Steel Patch Floor Cover Plate Decking	铝合金贴片楼层盖板/SUS304不锈钢贴片楼层盖板 Aluminum Alloy Floor Cover Plate Decking / SUS304 Stainless Steel Patch Floor Cover Plate Decking
围裙板(标配) Skirting Panel (Standard)	SUS430 不锈钢围裙板 SUS430 Stainless Skirting Panel	SUS430 不锈钢围裙板 SUS430 Stainless Skirting Panel
围裙板(选配) Skirting Panel (Optional)	SUS304 不锈钢围裙板 SUS304 Stainless Skirting Panel	SUS304 不锈钢围裙板 SUS304 Stainless Skirting Panel
踏板(标配) Pallet (Standard)	133.33mm铝合金银灰色 133.33mm Silver Grey Aluminum Alloy	133.33mm铝合金银灰色 133.33mm Silver Grey Aluminum Alloy
踏板(选配) Pallet (Optional)	133.33mm铝合金黑色 133.33mm Black Aluminum	133.33mm铝合金黑色 133.33mm Black Aluminum
扶手带(标配) Handrail (Standard)	黑色 Black	黑色 Black
扶手带(选配) Handrail (Optional)	其他颜色 Other Colors	其他颜色 Other Colors
扶手护栏(标配) Handrail Guardrail (Standard)	垂直 Vertical	垂直 Vertical
扶手护栏(选配) Handrail Guardrail (Optional)	—	—
护壁板(标配) Balustrade Panel (Standard)	10mm 钢化无色安全玻璃 10mm Toughened Tempering Safety Glass Colorless	10mm 钢化无色安全玻璃 10mm Toughened Tempering Safety Glass Colorless
护壁板(选配) Balustrade Panel (Optional)	—	—

型号 Model	KRF-RS	KLRP
踏板、梳齿板类型(标配) Types of Pedals and Comb Plate (Standard)	SUS430不锈钢贴片楼层盖板 SUS430 Stainless Steel Patch Floor Cover Plate Decking	SUS430不锈钢贴片楼层盖板 SUS430 Stainless Steel Patch Floor Cover Plate Decking
踏板、梳齿板类型(选配) Types of Pedals and Comb Plate (Optional)	铝合金贴片楼层盖板/SUS304不锈钢贴片楼层盖板 Aluminum Alloy Floor Cover Plate Decking / SUS304 Stainless Steel Patch Floor Cover Plate Decking	铝合金贴片楼层盖板/SUS304不锈钢贴片楼层盖板 Aluminum Alloy Floor Cover Plate Decking / SUS304 Stainless Steel Patch Floor Cover Plate Decking
围裙板(标配) Skirting Panel (Standard)	1.5mm SUS430 不锈钢围裙板 1.5mm SUS430 Stainless Skirting Panel	1.5mm SUS430 不锈钢围裙板 1.5mm SUS430 Stainless Skirting Panel
围裙板(选配) Skirting Panel (Optional)	SUS304 不锈钢围裙板 SUS304 Stainless Skirting Panel	SUS304 不锈钢围裙板 SUS304 Stainless Skirting Panel
踏板(标配) Pallet (Standard)	266.66不锈钢踏板 266.66 Stainless Steel Landing Plate	266.66不锈钢踏板 266.66 Stainless Steel Landing Plate
踏板(选配) Pallet (Optional)	—	400不锈钢踏板 400 Stainless Steel Landing Plate
扶手带(标配) Handrail (Standard)	黑色 Black	黑色 Black
扶手带(选配) Handrail (Optional)	其他颜色 Other Colors	其他颜色 Other Colors
扶手护栏(标配) Handrail Guardrail (Standard)	垂直 Vertical	垂直 Vertical
扶手护栏(选配) Handrail Guardrail (Optional)	—	—
护壁板(标配) Balustrade Panel (Standard)	10mm 钢化无色安全玻璃 10mm Toughened Tempering Safety Glass Colorless	10mm 钢化无色安全玻璃 10mm Toughened Tempering Safety Glass Colorless
护壁板(选配) Balustrade Panel (Optional)	—	—

土建参数 Parameter Construction Layout

KRF/KRF-B 室内 Indoor
KRF/KRF-B-800/1000

KRF-RS 室内 Indoor
KRF-RS-800/1000

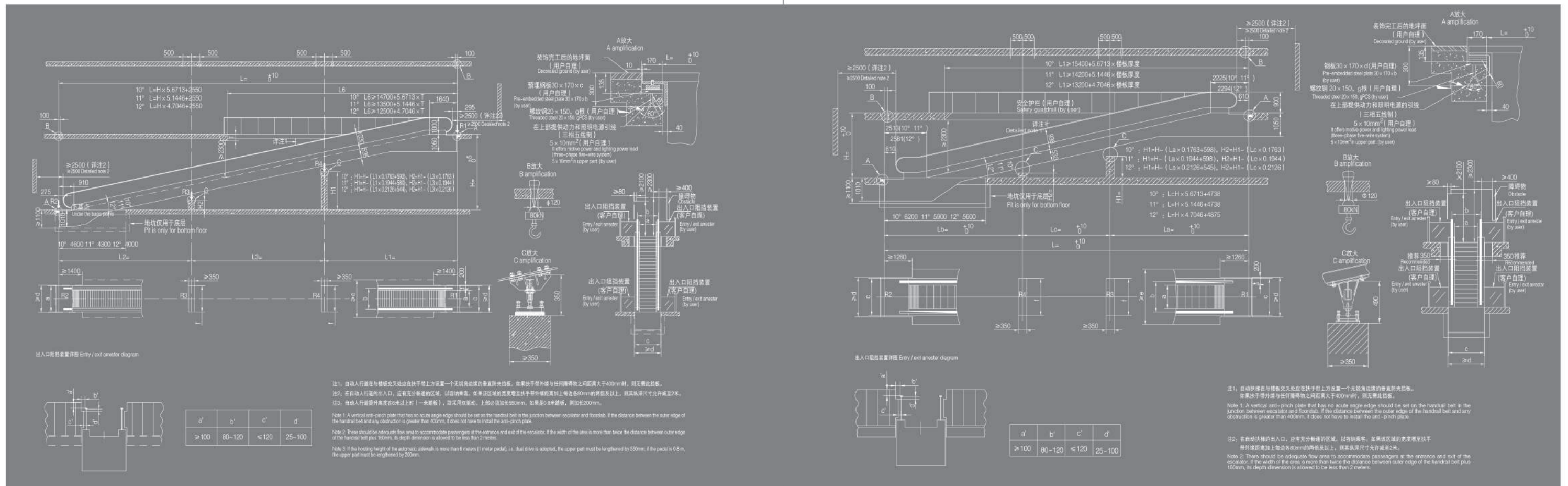

标准规格及尺寸 Standard specification and dimension

运行速度(0.5m/s)
Running speed(0.5m/s)

支承力 Supporting force		
Without middle supporting (kN) 无中间支撑	With one middle supporting (kN) 单中间支撑	With two middle supporting (kN) 双中间支撑
$R1=L \times q + M$	$R1=L \times q + M$ $R2=L \times q + N$	$R1=L \times q + M$ $R2=L \times q + N$ $R3=(L+Lc) \times 1.3 \times q$ $R4=(Lb+Lc) \times 1.3 \times q$

功率表 Power Table							
提升高度 Rise	3000	4500	5500	5600	6000	7000	8000
电机功率 Motor Power	1000	8kW	11kW	15kW	2x11kW		
电机功率 Motor Power	800	8kW		11kW		15kW	

备注 Notes: L, L1, L2单位为m, L1, L2都不超过15m
Unit for L, L1, L2 is m, L1, L2 are less than 15m

提升高度 Rise	q	M	N	踏板宽度 Pack width	
				800	1000
800	0.0039	9.5	4.5	f	1340 1540
1000	0.0045	11	5	g	5 6

倾斜角度 Angle	提升高度 Rise	中间支撑 Middle supporting		La	Lb	Lc
		R3	R4			
10°	1297	2178	-	-	-	-
	2179	4823	1	-	L/2	L/2
	4824	6600	1	1	L/3	L/3
11°	1449	2420	-	-	-	-
	2421	5335	1	-	L/2	L/2
	5336	7300	1	1	L/3	L/3
12°	1601	2645	-	-	-	-
	2645	5830	1	-	L/2	L/2
	5830	8000	1	1	L/3	L/3

标准规格及尺寸 Standard specification and dimension

- 1、本图适用于单台安装的自动人行道土建施工之用。
- 2、销售部门应将本图一式4份提供用户, 其中2份经用户盖章, 签字后返回技术科。
- 3、尺寸单位为mm, 个别尺寸可能有更改, 如有更改, 恕不另行通知。

1. His drawing is fit for the construction of 8m and below single mounted escalators.
2. The Sales Dept. needs to make four copies of this drawing. Two copies shall return to the Technical Section after being stamped and signed by the users.
3. Size unit: mm. It is possible to change some individual sizes. If there is any alterations, advance notice won't be given then.

标准规格及尺寸 Standard specification and dimension

运行速度(0.5m/s)
Running speed(0.5m/s)

支承力 Supporting force		
Without middle supporting (kN) 无中间支撑	With one middle supporting (kN) 单中间支撑	With two middle supporting (kN) 双中间支撑
$R1=L \times q + M$	$R1=L \times q + M$ $R2=L \times q + N$	$R1=L \times q + M$ $R2=L \times q + N$ $R3=(L+Lc) \times 1.3 \times q$ $R4=(Lb+Lc) \times 1.3 \times q$

功率表 Power Table							
提升高度 Rise	3000	3500	4000	4500	5000	5500	6000
电机功率 Motor Power	1000	8kW		11kW		15kW	
电机功率 Motor Power	800	8kW			11kW		

备注 Notes: L, L1, L2单位为m, L1, L2都不超过15m
Unit for L, L1, L2 is m, L1, L2 are less than 15m

提升高度 Rise	q	M	N	踏板宽度 Pack width	
				800	1000
800	0.0039	9.5	4.5	f	1340 1540
1000	0.0045	11	5	g	5 6

倾斜角度 Angle	提升高度 Rise	中间支撑 Middle supporting		La	Lb	Lc
		R3	R4			
10°	1297	2178	-	-	-	-
	2179	4823	1	-	L/2	L/2
	4824	6000	1	1	L/3	L/3
11°	1449	2420	-	-	-	-
	2421	5335	1	-	L/2	L/2
	5336	6000	1	1	L/3	L/3
12°	1601	2663	-	-	-	-
	2664	5851	1	-	L/2	L/2
	5852	6000	1	1	L/3	L/3

标准规格及尺寸 Standard specification and dimension

- 1、本图适用于6m以下单台安装的自动扶梯土建施工之用。
- 2、销售部门应将本图一式4份提供用户, 其中2份经用户盖章, 签字后返回技术科。
- 3、尺寸单位为mm, 个别尺寸可能有更改, 如有更改, 恕不另行通知。

1. His drawing is fit for the construction of 6m and below single mounted escalators.
2. The Sales Dept. needs to make four copies of this drawing. Two copies shall return to the Technical Section after being stamped and signed by the users.
3. Size unit: mm. It is possible to change some individual sizes. If there is any alterations, advance notice won't be given then.

土建参数 Parameter Construction Layout

KLRP 室内 Indoor
KLRP

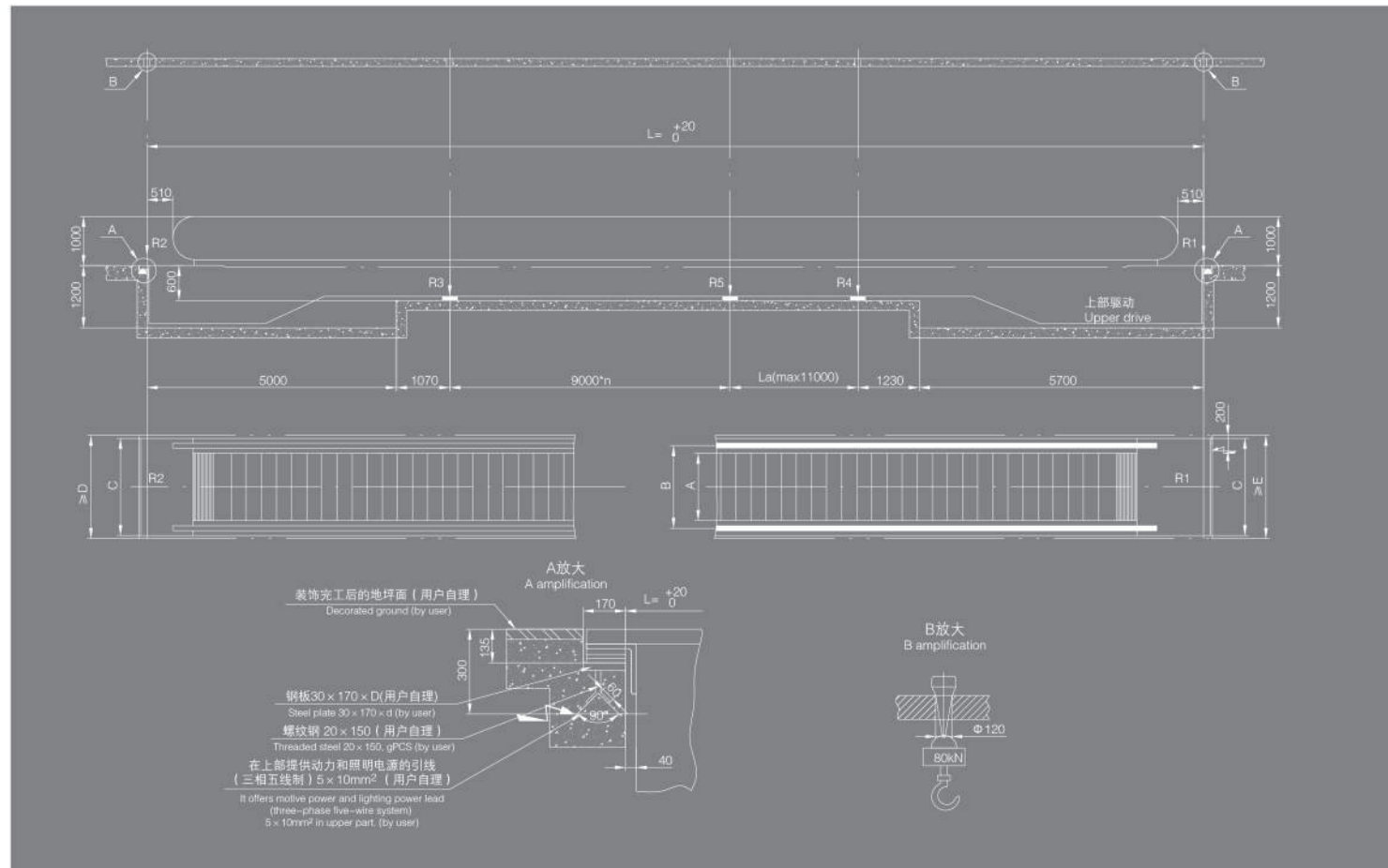

标准规格及尺寸 Standard specification and dimension

运行速度(m/s) Running speed(m/s)	0.5			
倾斜角度 Degree of inclination	0°			
踏板宽度(mm) Pallet width(mm)	800	1000	1200	1400
A	800	1000	1200	1400
B	1038	1238	1430	1648
C	1340	1540	1740	1950
D	1400	1600	1800	2010
E	1400	1600	1800	2010

说明 Description

- 1、本图适用于单台安装的自动扶梯土建施工之用。
- 2、销售部门应将本图一式4份提供用户，其中2份经用户盖章，签字后返回技术科。
- 3、尺寸单位为mm，个别尺寸可能有更改，如有更改，恕不另行通知。

1. The figure can be applied to the civil engineering and construction for the installation of single automatic moving walk.
2. The Sales Dept. needs to make four copies of this drawing. Two copies shall return to the Technical Section after being stamped and signed by the users.
3. Size unit:mm. It is possible to change some individual sizes. If there is any alterations, advance notice won't be given then.

全国分公司服务网络 National Branch Service Network

辽宁分公司

销售热线: 024-31981333 传真: 024-31981222
地址: 沈阳市大东区滂江街26-1国际公寓2916

大连分公司

销售热线: 0411-86552277 传真: 0411-86552299
地址: 大连市中山区民康街15号报业大厦16层E

盘锦分公司

销售热线: 0427-2828611 传真: 0427-2829611
地址: 辽宁省盘锦市兴隆台区大商新玛特C座2102室

黑龙江分公司

销售热线: 0451-82346098 传真: 0451-82318292
地址: 黑龙江省哈尔滨市道里区群力第四大道399号汇智广场西楼1004室

吉林分公司

销售热线: 0431-86770000 传真: 0431-81030300
地址: 长春市经济技术开发区临河街5445号圣豪汇商705室

北京分公司

销售热线: 010-65505559 传真: 010-65505562
地址: 北京市朝阳区八里庄西里97号住邦2000商务中心4号楼10层

内蒙古分公司

销售热线: 0471-6289116 传真: 0471-6922767
地址: 呼和浩特市回民区新华西街明泽广场A座21层2110室

河北分公司

销售热线: 0311-66792031 转 8002 传真: 0311-87893130
地址: 石家庄市建设南大街29号众鑫大厦818-820室

天津分公司

销售热线: 022-58306090 传真: 022-58306091
地址: 天津市红桥区光荣道与保康路交叉口宝能创业中心B座24层2412室

山西分公司

销售热线: 0351-8371869 传真: 0351-8371859
地址: 太原市小店区平阳路1号金茂国际数码中心A座16层F室

陕西分公司

销售热线: 029-88332244 传真: 029-88332244-831
地址: 西安市莲湖区唐延路北段22号金辉国际广场11层

甘肃分公司

销售热线: 0931-8811752 传真: 0931-8432645
地址: 甘肃省兰州市城关区澳兰名门B2座708室

新疆分公司

销售热线: 0991-4815313 传真: 0991-4815795-815
地址: 新疆乌鲁木齐沙依巴克区友好北路793号高地中心1105室

河南分公司

销售热线: 0371-60189221
地址: 郑州市郑东新区康平路永平路郑东商业中心写字楼一号楼17楼1707

山东分公司

销售热线: 0531-55693961 传真: 0531-55693965
地址: 济南市市中区经四路13号万达广场C座办公楼2606室

青岛分公司

销售热线: 0532-68890088 传真: 0532-89092106
地址: 青岛市市北区山东路177号鲁邦广场B座1106-1107

烟台分公司

销售热线: 0535-6887005 传真: 0535-6887005
地址: 山东省烟台市莱山区银海路566号南山世纪华府13-2-2802

南京分公司

销售热线: 025-58812988 传真: 025-84519155-81
地址: 南京市洪武路359号福鑫大厦西2602室

苏州分公司

销售热线: 0512-65166725 传真: 0512-65166721
地址: 苏州工业园区苏虹中路225号星虹国际1幢2113室

无锡分公司

销售热线: 0510-85861251 传真: 0510-85861252
地址: 无锡市滨湖区梁青路58号华邸国际大厦A座1501室

徐州分公司

销售热线: 0516-83919000 传真: 0516-83919005
地址: 徐州市庆丰路绿地城市广场瀛海写字楼A座706室

上海分公司

销售热线: 021-62828058/62827558 传真: 021-62828360
地址: 上海市延安西路1221号2203室

浙江分公司

销售热线: 0571-89971040 传真: 0571-86590365
地址: 杭州市新塘路19号采荷嘉业5幢1204室

安徽分公司

销售热线: 0551-62671797 传真: 0551-62313639
地址: 安徽省合肥市蜀山区望江西路69号西湖国际广场A座603室

芜湖分公司

销售热线: 0553-3856158
地址: 芜湖市镜湖区长江中路66号 徽商财富广场北楼1802室

江西分公司

销售热线: 0791-88223016 传真: 0791-88399056
地址: 南昌市高新开发区紫阳大道绿地新都会紫峰(幢)大厦写字楼34层3402室

湖北分公司

销售热线: 027-82660063 传真: 027-85770699
地址: 武汉市江汉区淮海路中段泛海国际SOHO城2605-2606室

襄阳分公司

销售热线: 0710-3287220 传真: 0710-3287220
地址: 襄阳市高新区长虹北路万达小区1栋二单元1902室

湖南分公司

销售热线: 0731-85787755 传真: 0731-85787722
地址: 长沙市岳麓区岳麓大道57号奥克斯广场B座1127-1129

重庆分公司

销售热线: 023-67877015 传真: 023-67877025
地址: 重庆市渝中区大坪正街160号万科锦程1栋26-6

四川分公司

销售热线: 028-61320037 传真: 028-87321179
地址: 四川省成都市高新区新世纪环球中心西区8-1-1707

云南分公司

销售热线: 0871-68355199 传真: 0871-68355299
地址: 云南省昆明市五华区人民中路36号如意大厦11A室

贵州分公司

销售热线: 0851-86515286 传真: 0851-86515286转81
地址: 贵阳市观山湖区金阳南路6号世纪城购物中心D栋写字楼23层5号

广西分公司

销售热线: 0771-5517626 传真: 0771-5505713
地址: 南宁市民族大道92-1号新城国际1401号

广东分公司

销售热线: 020-38021060 传真: 020-38021410
地址: 广州市天河区天河路625号天娱广场东塔1007-1008室

深圳分公司

销售热线: 0755-83865618 传真: 0755-83865618
地址: 深圳市福田区益田路3008号皇都广场A座1906室

珠海分公司

销售热线: 0756-2260550 传真: 0756-2260695
地址: 珠海市香洲区银桦路102号6栋优特科技大厦909室

福建分公司

销售热线: 0591-88596982 传真: 0591-88594630
地址: 福州市五一中路88号平安大厦21G